



FLORIDA'S CERTIFIED SMOKE MANAGEMENT PLAN 2014



Florida Department of Agriculture and Consumer Services
Adam H. Putnam, Commissioner

EXECUTIVE SUMMARY

Humans have used fire from the time they first set foot in what is now Florida. Native American use of fire for agricultural purposes, to enhance wildlife habitat, stimulate berry production, and to 'open up' the woods around their villages for protection from enemies and wildfire are well documented. The ability of fire to achieve these objectives is attested to by the fact succeeding cultures all quickly adopted this practice expanding both the reasons for, and acreage treated with fire. Fire continues to be a prime natural resource management tool, but its application has gotten much more complicated as Florida's population has transformed over the last 50 years as people and smoke do not mix well.

In 2010, 2,647,590 acres were treated with prescription fire in Florida. Hazard reduction and ecosystem restoration/maintenance burns dominated this acreage with 1,445,841 acres treated. The remainder of the acres referenced above fall into the categories of land clearing, agriculture, and the burning of wildlands for purposes like disease control, site preparation, and wildlife. The upward trend in acres treated over the past several decades suggests prescribed fire use in Florida will continue to increase into the foreseeable future. Fire is used in FL to accomplish dozens of objectives ; besides those mentioned above, it is used in the management of range, sugar cane, citrus, timber, flora, and fauna to name a few.

Florida certification of the updated Smoke Management Plan (SMP) described herein will provide a blueprint for Florida burn managers to use on fires they ignite and on wildfires they are tasked to suppress. The statutory basis behind this SMP can be found in Section VI. "Smoke Management Programs" of the U.S. Environmental Protection Agency's (EPA) "interim Air Quality Policy on Wildland and Prescribed Fires" dated April 23, 1998.

Environmental regulations, including the Clean Air Act and the National Ambient Air Quality Standards were established to address both visibility standards and criteria pollutants. EPA has authorized the Florida Forest Service (FFS) and Florida Department of Environmental Protection to implement and enforce federal regulations regarding air quality in the state. The State Forester is granted authority in Florida Statutes 590 and Florida Administrative Code 5I-2 to regulate open burning in Florida and serves as the Central Authority for the State's SMP.

The purposes of the Florida SMP are to mitigate public safety hazards (e.g. on roadways, in urban and exurban areas, and in the vicinity of airports) posed by smoke, to prevent deterioration of air quality including visibility impairment in Class I areas from wildland fire emissions, and to prevent National Ambient Air Quality Standards (NAAQS) violations.

The original Florida SMP was approved by EPA in 1999. That document was developed by the FFS and submitted to the Florida Department of Environmental Protection's Division of Air, which approved it and, in turn, submitted it to the EPA. At that time the FFS did not include input from other land managers whereas the update described herein has been reviewed and approved by a wide range of public and private natural resource managers in Florida.

Both the EPA interim air quality policy on fire (currently under revision), and the 2012 revision of the Exceptional Events Rule (originally published in 2007) (72 FR 13560) provide certain fire emission exemptions for states that implement an approved SMP. These changes are the prime reason for updating the Florida's current SMP. Additional reasons include 1) regional haze rules to improve visibility in Class I areas have also been strengthened; and 2) Increased prescribed fire emissions due to recent and projected increases in the use of prescription fire require increased coordination to prevent violating/exceeding the revised federal and state rules and standards.

Florida's Prescribed Burn Plan or Prescription

A burn plan or prescription is a key element of EPA's "Wildland and Prescribed Fire Policy." A written burn plan is required to conduct a Certified Prescribed Burn in Florida; it must include the following:

1. Stand or Site Description.
2. Map of the Area to be burned.
3. Control Lines (External and Internal) to be constructed.
4. Minimum number of personnel and pieces of equipment by type to be used on the prescribed burn.
5. Desired range of forecast weather factors, including surface wind speed and direction, minimum transport wind speed and direction, minimum mixing height, minimum relative humidity, maximum temperature, and the minimum fine fuel moisture.
6. Desired fire behavior factors, such as firing technique(s), flame length, and rate of spread.
7. Time and date the prescription was prepared.
8. Authorization date and time period of the authorization.
9. Evaluation of anticipated impacts on identified smoke sensitive areas and signature of approving official.
10. Signature and number of the Certified Prescribed Burn Manager.

Certified Pile Burners must include the following elements in their burn plans:

1. Burn location.
2. Soil type and moisture.
3. Number of personnel and equipment types to be used on the pile burn.
4. Desired weather factors, including but not limited to surface wind speed and direction, minimum relative humidity, Drought Index, days since rain, maximum temperature, and the Dispersion Index.
5. Fuel type and condition (how long has it been drying).
6. Time and date the plan was prepared.
7. Authorization date and time period of the authorization.
8. Evaluation of anticipated impacts on identified smoke sensitive areas and signature of approving official.
9. Adjacent landowners to notify.
10. Special precautions.
11. Signature and number of the Certified Pile Burner.

The FFS, in cooperation with the Florida Department of Environmental Protection's Division of Air, annually collect and review information on prescribed fire and wildfire to evaluate the effectiveness of the SMP. Representatives of these two state agencies address any violations that occurred, and propose modifications to existing operating procedures to correct identified concerns and disturbing trends.

TABLE OF CONTENTS

EXECUTIVE SUMMARY	1
TABLE OF CONTENTS	4
CHAPTER 1. INTRODUCTION	6
1.1 Background	7
1.2 Reasons for revising the Smoke Management Plan	8
1.2.1 EPA interim Policy and Guidance	8
1.2.2 Maintaining compliance with umbrella state and federal statutes/policy	9
1.2.2.1 Florida acreage treated with prescription fire is projected to continue to increase	10
1.2.2.2 No violations of the NAAQS due to emissions from managed fires have occurred since the current Florida SMP was certified in 1999.	11
CHAPTER 2. COMPLIANCE	11
2.1 ENVIRONMENTAL REGULATIONS	11
2.1.1 Clean Air Act Amendments (CAAA) and Visibility	11
2.1.2 Visibility Emissions from Fire	12
2.2 AGENCY AUTHORITY	13
Florida Department of Agriculture and Consumer Services (FDACS), Florida Forest Service Responsibilities and Role as SMP Authority	13
CHAPTER 3. THE SMOKE MANAGEMENT PROGRAM REQUIREMENTS	15
3.1 AUTHORIZATION TO BURN	15
3.2 BURN PLANS	15
3.2.1 Burn Plan Elements	15
3.2.2 Smoke Management Components of Burn Plans	16
Actions to Minimize Fire Emissions	16
Evaluate Smoke Dispersion	17
Public Notification and Exposure Reduction Procedures	17
Air Quality Monitoring	17
3.2.3 Smoke Management and Dispersion	18
3.2.4 Suggested Smoke Screening Systems	19
Executing a Smoke Screening System	19
3.2.5 Florida Fire Management Information System (FMIS) Smoke Screening Tool	21

3.2.6 Manual Smoke Screening System22

3.2.7 Manual Screening System for Managing Smoke in the Wildland Urban Interface (WUI) ...26

CHAPTER 4. Public Relations and Image Management.....37

4.1 PUBLIC EDUCATION AND AWARENESS37

4.2 SURVEILLANCE AND ENFORCEMENT.....37

4.3 OPTIONAL AIR QUALITY PROTECTION37

GLOSSARY38

LITERATURE CITED.....43

APPENDIX.....45

FLORIDA FOREST SERVICE RX FIRE PLAN.....46

BURN PLAN FOR PILE BURNERS48

NATIONAL WEATHER SERVICE, FIRE WEATHER WEBSITES.....49

THE AIR QUALITY INDEX (AQI)50

2013 FDEP REGULATORY DISTRICTS, LOCAL AGENCIES, AND MONITORING SITES51

CHAPTER 1. INTRODUCTION

Many fire ecologists believe wildland fire has been an integral part of the Florida landscape ever since lightning first struck a receptive fuel complex eons ago. The native species that thrive in this subtropical landscape fall into two categories, those that are fire dependent and those that are fire maintained. By species we are not only referring to the flora; fauna too have developed peculiarities that are specific to ecosystems born of fire. Natural fires were augmented by human ignitions soon after the first emigrants found their way into this region more than 13,000 years ago.

The first Europeans arriving in the 16th century marveled at the frequency of fire on this land and its propensity to burn even when green.

...on the nine and twentieth of August a lighting from heaven fell within halfe a league of our Fort, more worthy I beleve to be wondered at, and to bee putin writing, then all the strange signes which have bene seene in tiems past, and whereof the histories have never written. For although the medowes were at that season all greene, and half covered over with water, nevertheless the lightning in one instant consumed above five hundred acres therewith, and burned with the ardent heate thereof all the foules which tooke their pastime in the medowes, which thing continued for three days space... (de Laudonniere 1587; near Fort Caroline, Florida, p.31)

They quickly realized the benefits of fire and embraced the Native American use of fire to increase the productivity of a site e.g., grasslands, berry production, and to attract or drive game species. Prior to the industrial revolution, fire was the only tool humans had to modify the landscape. However by the 1920's the pendulum had begun to swing from the ubiquitous use of fire to fire exclusion as old forests were turned into lumber and new ones struggled to establish themselves on lands that were cut over, grazed over and burned over. It was patently obvious to the professional foresters that began to come South after WWI that fire was the culprit – a misconception shared by many new arrivals. These newcomers succeeded in making their view of federal and state policy, however wildland systems change rapidly in Florida's subtropical environment and the fire exclusion policy soon produced disastrous results. Within a decade there was a general movement afoot to return fire as a management tool to keep Florida's wildlands in balance and the US Forest Service (USFS) lifted its ban on using fire on national forests in Florida in 1943.

As Florida's population grew and produced the inevitable associated infrastructure, the use of fire as a management tool came into increasing conflict with the growing urban and exurban population. The conflict centered around reduced visibility on Florida's roadways and air quality issues voiced by the millions of new arrivals to Florida from other parts of the country where this type of natural resource management was unheard of in the late 20th century. The Florida Forest Service (FFS) and Legislature have led the nation in thoughtfully addressing this problem. In 1977 the Hawkins Bill was passed which allowed the FFS to treat private lands that their staff had identified as a serious fire hazard. No other natural resource agency in any other state had anything remotely like this

authorization; it provided mute testimony to the dangerous threat untreated fuels place on Florida's population and on the FFS which is responsible for fire suppression.

In 1987, the Florida Forest Service developed additional precedent setting fire management solutions. Looking at the wide range in burner proficiency and the cavalier attitude of some burners, particularly regarding emissions from their fires, coupled with increasing pressure a concerned public was placing on local and state legislators to restrict what they perceived as the wanton use of fire, the FFS determined they had to either increase restrictions and enforcement, or improve the quality of burn execution. They concluded the best approach was to educate burners regarding their legal and good-neighbor responsibilities; to provide basic information on fire behavior, fire weather, fuels, firing techniques and smoke management; and to train burn managers how to use this information to plan and execute a burn to accomplish natural resource objectives with minimal offsite impacts. The FFS also recognized the value of providing incentives for burners to attain and use this knowledge. The result was Florida's Certified Prescribed Burn Manager program which involves pre-work, a rigorous week of classroom and field exercises, a final exam and a signed affidavit affirming demonstrated proficiency on three operational burns and a certification burn. This program is offered at various locations throughout the state several times a year and since its inception in 1988, more than 4,000 natural resource managers have become certified. Companion legislation called the Florida Prescribed Fire Act was introduced and passed by the Legislature in 1990. This groundbreaking statute has been copied by many other states and is remarkable on two counts: One, it identifies burning as a property-owner right in the public interest if conducted under appropriate rules, and limits liability to "gross negligence" for Florida Certified Burners thereby protecting them from frivolous litigation. "The second innovation was to give the FFS authority to determine what the guidelines and suitable rules might be" (DOF: Florida's Fire Fulcrum, Pyne 2011).

1.1 Background

In Florida, both public and private sector managers routinely use fire to achieve natural resource objectives including woodland owners, farmers; ranchers; non-agricultural landowners; all state and federal natural resource agencies; the university system; all water management districts; all Department of Defense installations; all Native American tribal governments; nature preserves; residential community homeowner associations; corporations; real-estate investment trusts; The Nature Conservancy; Audubon Society; Archbold Biological Station; Tall Timbers Research Station; municipalities and city/county park/green-space managers. In other words, just about all natural resource managers. When used wisely, following sound resource management planning based on years of investigation and close observation, fire has repeatedly proven itself to be a safe, cost effective, indispensable and irreplaceable tool to the natural resource management community.

In 2010 a record 2,647,590 acres and 123,116 piles were intentionally treated with fire in Florida. This increase was due both to more frequent treatment on lands already managed with fire as well as by expanding this rejuvenating natural force to additional lands. The

majority of wildland and agricultural acres treated were for hazard reduction, ecological objectives, wildlife habitat improvement, range/pasture improvement, and to facilitate sugar cane harvest. Most pile burning was associated with land use changes.

All fires produce combustion products that include solid and gaseous air pollutants, but fires vary widely in the types and amounts of combustion products produced. Characterizing and managing air pollution from prescription fires requires knowledge of the type and amount of pollutants emitted and the stage of combustion during which they are released. Fire is a complex process comprised of four combustion stages all of which produce an array of combustion products depending on the amount of oxygen available, the temperature at which the chemical reactions take place, and the physical and chemical attributes of the live and dead fuel complex involved including the moisture present. All these factors change spatially and temporally depending upon physiographic features such as slope, aspect and soil type, and on meteorological variables such as wind velocity, humidity, precipitation and solar radiation. Fire behavior changes in response to changes in each of these myriad interconnected facets that combine to determine combustion rate, residence time, rate of spread, and flame length which in turn determine fireline intensity, fire severity and emissions. The amount, rate, and nature of pollutants thus varies widely and characterizing them is difficult at best requiring explicit in-depth knowledge of fuel bed characteristics and condition, combustion environment, and fire behavior.

1.2 Reasons for revising the Smoke Management Plan

There are three main reasons for revising the Florida Smoke Management Plan (SMP). The most obvious and most important reason is to embrace new information that will help protect the health of Florida residents. The two other reasons are associated with the consequences of burning, and to keep the SMP compliant with umbrella state and federal statutes. Each of these reasons is discussed in the following sections. The existing Florida regulations on agricultural and wildland burning were originally written to deal with safety, specifically wildfire safety and visibility impairment from smoke on public roads and around airports. These regulations can be found in the 2014 publication, Florida's Forest Fire Laws and Open Burning Regulations.

1.2.1 EPA interim Policy and Guidance

“The purpose of SMP’s are to mitigate the nuisance and public safety hazards (e.g., on roadways and at airports) posed by smoke intrusions into populated areas; to prevent deterioration of air quality and the National Ambient Air Quality Standards (NAAQS) violations; and to address visibility impacts in mandatory Class 1 Federal areas” (EPA 1998). The NAAQS referred to above are for particulate matter (PM) <2.5 microns (PM2.5) and particulate matter <10 microns (PM10).

According to the EPA “Interim Air Quality Policy on Wildland and Prescribed Fires” (April 1998), if any of the following statements are true, it is a “strong indication” that a statewide SMP would be beneficial:

1. Citizens increasingly complain of smoke intrusions.

2. The trend of monitored air quality values is increasing (approaching the upper limit for daily or annual NAAQS for PM_{2.5} or PM₁₀).
3. Fires cause or significantly contribute to monitored air quality that is already greater than 85 percent of the daily or annual NAAQS for PM_{2.5} or PM₁₀; or
4. Fires in the area significantly contribute to visibility impairment in Class I areas.

Since the Florida SMP was implemented in 1999, none of these conditions have been present in Florida. For example, the annual values of PM_{2.5} concentrations in the forested parts of Florida are well below the 85 percent level of the NAAQS standard based on over 10 years of data. Although these conditions don't currently exist in Florida, the nature of the SMP is preventive. The natural resource management community is in general agreement that a statewide SMP to minimize smoke impacts and address prescription fire emissions is good public policy and all Florida fire managers must continue to work as a team to ensure smoke from their burns does not impair air quality.

1.2.2 Maintaining compliance with umbrella state and federal statutes/policy

Regional haze rules to improve visibility in Class 1 areas affect Florida. Section 169A of the Clean Air Act Amendments (CAAA) of 1977 set forth "...the national goal of preventing any future, and remedying any existing, impairment of visibility in Class I Federal areas which [where the] impairment results from man-made air pollution." The EPA issued rules in 1980 that include language directed at "reasonably attributable" sources of visibility impairment. With the addition of section 169B to the Clean Air Act (CAA) of 1990, Congress addressed "regional haze" visibility in the nation's national parks and wilderness areas. The EPA has determined that all 156 Class I areas across the nation demonstrate impaired visibility based on Interagency Monitoring of Protected Visual Environments (IMPROVE) monitoring data. Chassahowitzka National Wildlife Refuge, St. Marks National Wildlife Refuge, Okefenokee Wildlife Refuge (because of its proximity) and Everglades National Park are "mandatory Class I areas." Bradwell Bay Wilderness Area is not included in this group because it is not listed among the mandatory Federal Class I areas identified in 40 CFR 81, Subpart D, §81.407 as being subject to visibility protection. All of the listed Class I areas have IMPROVE monitors for determining components of haze, which may impair visibility.

EPA published final regional haze regulations on July 1, 1999 (64 FR 35714). The rules are directed at four emission sources of visibility impairment: stationary sources (industry), mobile sources (vehicles), area sources (e.g., gas stations, dry cleaners, etc), and prescribed fire. The pollutants most responsible for haze include nitrates, sulfates, soil material, organic carbon, and elemental carbon. The last two are found in smoke from vegetative burning or are derived from combustion products produced in wildland fire. Ozone is a byproduct of fire emissions and when further subjected to sunlight, can contribute to downwind particle formation i.e., haze. The goal of the regional haze program is to show continuous improvement in monitored visibility in Class I areas so that natural background conditions are restored by 2064. The rules require that each state submit a State Implementation Plan (SIP) to the EPA to implement emission reductions necessary to improve visibility in parks and wilderness areas. At this time smoke from prescribed fires

has been shown to be a minor contributor to the long term visibility evaluation for Class One Areas identified in the regional haze plan.

1.2.2.1 Florida acreage treated with prescription fire is projected to continue to increase.

There is a nationwide trend by natural resource managers, both public and private, to: 1) increase the use of prescription fire to reduce hazardous fuel accumulations that are largely due to fire exclusion, 2) improve habitat for native flora and fauna, and 3) restore ecosystem biodiversity and productivity. Burners are frequently criticized by the public for perceived damage to a particular species or community of concern. But if you step back and look at the big picture you will see that the resulting system post burn is far more productive and healthy than prior to a well-timed and executed burn.

Data compiled by the Florida Forest Service for prescribed burning in 2010 shows that prescribed fire was applied to a total of 2,647,590 acres and 123,116 piles. Since inception of the Prescribed Fire Act in 1990 and the original SMP in 1999, Florida has seen a 15 to 20% increase in acres treated due to an increase in the frequency of fire on lands already managed with fire as well as returning fire to land where it had been temporarily excluded. The exact figure is difficult to determine because the acreage burned fluctuates based on the severity of the wildfire season and on timing and amount of precipitation within a given year. We suspect this increase is in large measure due to the increased public realization that: 1) the intentional use of fire is the only practical way reduce the specter of catastrophic wildfire, 2) the more frequently prescription fire is applied, the lower the potential for damaging wildfire, and 3) the visually apparent aesthetic, ecological and economic benefits on Florida lands managed under an appropriate fire regime, many for more than half a century. This acreage includes lands both within and adjacent to Class 1 areas.

Class 1 areas in Florida are administered by three federal land management agencies (National Park Service, USFS, and Fish & Wildlife Service). All three use prescribed fire extensively to improve and maintain the health of ecosystems in Class I areas, and it is essential they continue to do so in a manner that also minimizes the effects of these fires on visibility. The process of improving visibility in Florida's most valued and scenic landscapes will be very lengthy and difficult. As industrial, mobile, and area sources are required to reduce visibility pollutants, land management agencies will also be expected to use effective smoke management methodologies. While the other source types mentioned above are entirely "man-made," it must be remembered that the vegetation types in Florida's Class 1 areas are fire dependent or fire maintained, hence smoke from fires was present presettlement and is thus considered a component of natural background visibility in our state. The same is true for the Okefenokee NWR in Georgia; none-the-less, because of the 50 mile buffer for Class 1 areas, Florida burners have to be careful not to negatively impact the Okefenokee NWR with emissions from their burns.

1.2.2.2 No violations of the NAAQS due to emissions from managed fires have occurred since the current Florida SMP was certified in 1999.

Managed fire is one activity addressed by the regional haze rules that can contribute to visibility impairment in Florida's Class 1 areas. Since implementation of the Florida SMP, measured emissions from prescribed fires have decreased and no violations of NAAQS or state air quality standards have occurred. Furthermore, as explained in the EPA interim guidance document, it states that if a state implements a Certified SMP, and a managed fire significantly contributes to a violation of the PM10 or PM2.5 standards, EPA will exclude the monitor/s data so that the area will not be reclassified as non-attainment. This incentive provided by the EPA for implementation of an SMP has been very important where an area of a state exceeded the air quality standards due to smoke from prescribed burning. The EPA is developing new guidance for wildland and prescribed fires scheduled to be completed in 2014.

EPA finalized the "exceptional events" rule (72 FR 13560) in 2007. Exceptional events include natural events and unusual human activity events where ambient air measurements resulting in an exceedance can be excluded from the data used to show compliance with ozone and PM standards (NAAQS). The rule states "wildfires" and "wildfire use" fires are deemed "natural events." Certain prescribed fires may also be considered exceptional events if they meet specific criteria, one of which is the use of a state-certified SMP for those fires (40 CFR Parts 50 51, Treatment of Data Influenced by Exceptional Events; Final Rule).

If an area of a state violates the NAAQS, the state must prepare a SIP and submit it to the EPA for approval. The SIP sets forth measures that the state will undertake to reduce levels of air pollution and return non-attainment areas to compliance with the standards. Air monitors for PM2.5 and PM10 collect air samples that are analyzed to measure compliance. Monitoring data can also be used to support computer air models. Air modeling is done to determine the source of pollutants and the effect of emission reductions on concentrations of those pollutants. SIP requirements can include restrictions on construction of new sources of emissions, or emission reductions on existing sources whose emissions contributed to the violations. Once EPA approves a SIP, its' conditions become federally enforceable. At that time, facilities and other sources addressed in the SIP are accountable to both the State and EPA for a compliance schedule of emission reductions.

CHAPTER 2. COMPLIANCE

2.1 ENVIRONMENTAL REGULATIONS

2.1.1 Clean Air Act Amendments (CAAA) and Visibility

The CAAA requirements regarding visibility and regional haze date from 1977 when Congress addressed sources and air pollutants which "...may reasonably be anticipated to

cause or contribute significantly to impairment of visibility.” In 1980 the EPA issued rules addressing “reasonably attributable” sources of visibility impairment. That is to say, individual sources or groups of sources whose emission ‘plumes’ could be observed to affect the air in Class 1 areas.

In 1990, Congress amended the CAAA again and added requirements addressing regional haze, including rulemaking by EPA. In 1999, EPA published final rules that required SIP submittals by all states and implementation of “reasonable progress goals” for all Class I areas. Florida’s approved regional haze SIP, for the first planning period 2008-2013, includes emission reductions necessary to meet a goal of showing continuous improvements in visibility in Class I areas on the 20% “worst” days and no degradation of visibility on the 20% “best” days, as determined by IMPROVE monitoring data. The national goal is to achieve “natural background” visibility in all Class I areas by 2064. In order to achieve the emission reductions necessary to reach this ultimate goal, the regulatory agency through a series of ten-year plans, will consider the potential for reductions from all sources of visibility – impairing pollutants in the state, including open burning (Agriculture, Silviculture and Land Clearing). EPA and states are now including prescribed burning and wildfires in their analysis of visibility (up until recent years, insufficient data were available to include these sources), and the previous certified SMP as well as this revised SMP will be submitted as an attachment to the periodic regional haze SIP.

2.1.2 Visibility Emissions from Fire

Both the scattering and absorption of light by particles in the atmosphere reduce visibility. Light transmission is inversely related to the concentration of small particles in the air. Given that relationship, measured PM_{2.5} levels can be used to calculate visibility impairment. IMPROVE monitors measure different types of PM_{2.5} and PM₁₀ allowing determination of the effect of different pollutants on visibility.

Besides water vapor, vegetative burning produces several combustion products that directly or indirectly affect visibility including nitrogen oxides (NO_x), organic compounds, and PM. Ozone, which can form “smog” or haze, is not directly produced by fires, but from NO_x and volatile organic compounds or VOCs. Sunlight reacts photochemically with these ozone precursors to produce ozone as a smoke plume moves downwind. Approximately 90% of the particulate matter produced in wildland fire falls into the PM₁₀ or less category and about 70% is PM_{2.5} or smaller category.

Both particulate matter and ozone are “criteria” pollutants, meaning they are specifically listed in the NAAQS and thus have established upper limit concentrations. Thus wildland fire emissions can contribute to violations of these standards. There are no national or state air quality standards for organic or elemental carbon particles. However, these particles are measured by the IMPROVE monitors as a PM_{2.5} compound, and will be used to assess long-term improvement in visibility. IMPROVE monitors measure sulfates, nitrates, and organic and elemental carbon which are all PM_{2.5} and PM₁₀. The IMPROVE

monitors inside or adjacent to the Class I areas can be considered “compliance” monitors used to assess reduction in regional haze due to all visibility pollutants.

2.2 AGENCY AUTHORITY

Florida Department of Agriculture and Consumer Services (FDACS), Florida Forest Service Responsibilities and Role as SMP Authority

The State Forester serves as the Authority for the State’s Smoke Management Plan (SMP) and is granted authority in Florida Statute 570.07(28) and 590.02 to control open burning “For purposes of pollution control and the prevention of wildfires, to regulate open burning connected with land-clearing, agricultural, or forestry operations.” The State Forester currently delegates this authority to designated District/Center Managers within the FFS Operations Bureau.

Open burning is controlled through an authorization program. During periods of higher fire danger, the local District/Center manager may cancel all open burning authorizations within their area. If conditions worsen, the State Forester can shut down all burning state wide, and he or she can designate certain exceptions e.g., an agricultural burn that is in the middle of a plowed field and thus does not pose an escape threat. If conditions worsen further, the Commissioner of Agriculture can step in, and with approval of the Secretary of State, shut down all burning and limit access for off road vehicle traffic until precipitation breaks the drought.

Anyone (this includes federal, state, private, or local government) who wants to conduct an “open burn” in Florida, defined as any burn where the smoke is not routed through a chimney, must have an authorization from the FFS unless it is considered commercial burning or backyard vegetative waste (yard waste). Yard waste burns are exempted as long as the burner adheres to the state’s restrictions for this type of burning listed below in section 3.1 **Authorization to Burn**. If they burn without meeting the required restrictions, they are considered to be burning without authorization and thus in violation of the law.

Obtaining authorization for a burn in Florida is accomplished by calling the local FFS office and requesting authorization. There are 15 locations in Florida that issue burn authorizations. The office will set up an account for the burner, and collect address and contact information. Once the account has been established, the communications center will process the request. The burner may call after 4:00 PM the day before the burn, or any time before ignition the day of the planned burn. The duty officer will collect pertinent information concerning the burn, such as purpose, number of acres, planned ignition time, and land owner of record. This information is put into the Fire Management Information System (FMIS). After the FFS has this information, they locate the burn on a map and project a smoke plume from the burn site by coupling the most sophisticated weather model publicly available with the HySplit smoke dispersion model. If the plume impacts an area that has been identified as smoke sensitive by the FFS, the duty officer is required to get a local supervisor to approve the burn. This may require an onsite inspection before the burner can receive authorization. The burn may be set back a day or two because of

this, depending on the limitations set by the local supervisor. Those who burn on a regular basis are aware of this requirement and often request the local supervisor to come out before they call for authorization so that they already have an onsite inspection done and know what weather parameters the local supervisor is going to require for them to obtain authorization.

There is no requirement, at this time for a burner to contact the FFS with actual accomplishment acres. For this reason the acres listed in the FMIS system are “planned” acres, not actual accomplished acres.

If a burn is judged to be creating a problem for any reason, the FFS will require the burn be brought into compliance. The burner has two hours to bring the burn into compliance, unless public health and safety are immediately threatened. If the latter is the case, the FFS will suppress the fire, and the burner/landowner will receive a suppression bill from the FFS.

The FFS issues authorizations for both daytime and nighttime burns. Nighttime authorizations are contingent on the forecast Dispersion Index (DI). The DI is an indicator of the atmosphere’s ability to move air, and thus smoke away from a burn site and dilute it to the point that it will not appreciatively impact air quality. The required nighttime DI value depends on location of the burn and burner credentials. Florida has setup specific areas that are sufficiently remote to accommodate nighttime burns without negative smoke impacts. However, the minimum acceptable DI value of three (3) is only available to burners that have been issued a Prescribed Burn Manager Certificate (PBMC) by FFS. Outside these designated areas, the minimum nighttime DI threshold is six (6) for certified burners and eight (8) for those without certification. The air quality impacts of a nighttime burn are strongly dependent on the accuracy of the forecast weather and the predicted DI. Although the DI is an important consideration when planning a daytime burn, there are no daytime operational thresholds pertaining to burn authorizations. Florida Forest Service training stresses that transport winds below 9 mph and mixing height below 1640 ft or 500 meters are likely to temporarily reduce air quality to a point that will generate complaints from the local population or worse, cause visibility problems on roadways and medical/respiratory problems in local communities.

CHAPTER 3. THE SMOKE MANAGEMENT PROGRAM REQUIREMENTS

3.1 AUTHORIZATION TO BURN

An authorization issued by one of the 15 FFS District/Centers must be obtained, and an authorization number assigned; there is no charge for these authorizations. The authorization may be obtained over the phone, or with the assistance of a FFS employee via the FFS radio system. Certified Prescribed Burn Managers and anyone requesting authorizations for pre-harvest sugar cane burns can use the FFS online web page. The online system requires the user have an account with the FFS prior to their first request for a burn authorization. They can call one of the 15 locations that issue authorizations to set up their account. At this point they will be issued a temporary password; their user name will be their customer number. When they use the system for the first time they will be required to change their password to a permanent one. They place their request and the office that is in charge of the section of the state where they want to burn will review the request and approve/deny or put it on hold for an on-site-inspection.

Authorization to conduct an open burn is not required for yard waste burns that meet the required setbacks (found in the Open Burning Rules and Regulations of 2014) and is either in a container with a screen over top or no larger than 8 ft in diameter. There is also no requirement for recreational fires, cooking fires or fires used to warm workers. These types of fires must be monitored from start to extinguishment, and may only contain clean dry wood; no treated wood or other materials including paper are permitted in these types of fires.

The FFS may set special requirements for authorizations, (certified or non-certified), in order to protect public health and safety, including; on-site inspections; restricting wind direction and/or limiting the burning period within a day, or to a specific number of days for authorizations that allow multiple burn days; halting or limiting burning when fire danger is too high in all, or specific parts of the state; and requiring specific personnel and/or control equipment on-site during a burn.

3.2 BURN PLANS

3.2.1 Burn Plan Elements

Written burn plans are only required for burns requested by a Certified Burner to have certification status. Neither Certified Prescribed Burn Managers nor Certified Pile Burners are required to certify all their burns. However, they lose their exemption from civil liability if they chose not to have a burn listed as certified. Most agency burning is conducted based on a written plan as part of the individual agency policy. The complexity of these plans is entirely up to the land management agency in question. However, if the burn is listed as certified, the state of Florida has a set of minimum required elements for the plan that include:

- Stand or site description.
- Map of the Area to be burned.
- Control Lines (External and Internal) to be constructed.
- Minimum number of personnel and pieces of equipment by type to be used on the prescribed burn.
- Desired range of forecast weather factors, including surface wind speed and direction, minimum transport wind speed and direction, minimum mixing height, minimum relative humidity, maximum temperature, and the minimum fine fuel moisture.
- Desired fire behavior factors, such as firing technique(s), flame length, and rate of spread.
- Time and date the prescription was prepared.
- Authorization date and time period of the authorization.
- Evaluation and approval of the anticipated impact of the proposed burn on related smoke sensitive areas (SSAs).
- Signature and number of the Certified Prescribed Burn Manager.

These plans must be kept on file for a minimum of four years from the date of the fire in the event it becomes necessary to demonstrate an Exceptional Event per Environmental Protection Agency 40 CFR Parts 50 and 51, Treatment of Data Influenced by Exceptional Events; Final Rule, for the necessary time that DEP is required to report data to the EPA. In 2013, the duration is 4 years. Records should include burn plans along with 1) actual acres burned, 2) associated fuel types (Fire Behavior Prediction System (FBPS) models either the 13 or 40), and 3) any smoke monitoring done, such as visual observations or particulate measurements.

3.2.2 Smoke Management Components of Burn Plans

Actions to Minimize Fire Emissions – The burn plan should document the steps to be taken prior to, during, and after the burn to manage air emissions. This includes measures taken to reduce residual smoke, such as rapid complete mop-up, mop-up of certain fuels, etc. Where applicable, utilize one or more of the following approaches to reduce emissions.

- Choose a non-fire treatment as a pseudo-surrogate for fire. This option cannot provide a long-term solution as ecosystem health will invariably deteriorate over time with some components disappearing within just a few years. An appropriate fire management regime is required to perpetuate *every* native terrestrial ecosystem in Florida. Fire is truly *THE ecological imperative*.
- Reduce the area burned on a given day. The acres not burned today will, however, need to be burned another day to meet natural resource objective(s).
- Reduce the amount of fuel consumed by burning when larger fuels or duff have sufficient moisture levels to keep them from igniting. Often these fuels will still be present the next time the unit is scheduled to be burned.

- Reduce smoldering combustion which produces more than twice as much particulate as flaming combustion by using a backfire and by performing rapid complete mop-up. Rapid complete mop-up is, however, not economically feasible on burns larger than a few acres.

Evaluate Smoke Dispersion – In Florida, only Certified Prescribed Burn Managers can conduct Certified Burns; when choosing to do so, the manager is required to include an evaluation of potential smoke impacts at sensitive receptors, and he or she must time fires to minimize exposure of sensitive populations (i.e., those to whom smoke may present particular health risks), and to do their best to avoid serious visibility impacts in Class I areas. Sensitive receptor sites are defined as locations where human populations are concentrated and where smoke is likely to impact the health or safety of those populations or significantly impact visibility that may be detrimental to either health or the enjoyment of scenic landscapes. These may be residential concentrations, or locations where people tend to gather in groups such as parks. Travel routes such as major highways/Interstates are also smoke sensitive receptor sites where smoke has the potential to cause accidents by reducing visibility. Particular areas along highways or other locations may be more prone to smoke problems because of topographic and/or microclimate features such as near ponds, swamps, marshes etc. and these should be addressed in the burn plan. The prescribed burn plan should identify all sensitive receptor sites within the plotted ‘probable smoke impact area’ and within 1,000 feet in every direction of the burn when aged stumps and/or down dead material larger than 3” in diameter are present. Prescriptions/plans must specify minimum requirements for the atmospheric capacity to disperse smoke such as minimum surface and upper level wind speeds, desired wind direction, minimum mixing height, and dispersion index. The DI can be used for this purpose as described in section 3.2.3.

Public Notification and Exposure Reduction Procedures – The plan should identify actions that will be taken to notify populations and authorities at sensitive receptors, including those in adjacent jurisdictions, prior to the planned burn. The plan should also identify contingency actions that will be taken during a fire to reduce the exposure of people at sensitive receptors if smoke intrusions occur.

Air Quality Monitoring – The plan should identify how the effects of the fire on air quality at sensitive receptors, and visibility in Class I areas will be monitored. The extent of the monitoring plan should match the size of the fire. For small, or short duration fires such as those in grass or leaf litter, visual monitoring of the directions of the smoke plume and monitoring nuisance complaints by the public are sufficient. Other monitoring techniques include posting personnel on vulnerable roadways to look for visibility impairment and initiate safety measures for motorists, posting personnel at other sensitive receptors to look for smoke intrusions, using aircraft to track the progress of smoke plumes, and continued tracking of meteorological conditions during the fire. Wildland fire managers thus need to know the location of pertinent DEP Division of Air monitors. In the unlikely event that a planned burn impacts a monitor to the extent that a National Ambient Air Quality Standard is exceeded, the information contained in the plan and the monitoring

that the Burn Manager initiated will be needed by the Division of Air in order to gain an EPA exception for those monitoring data.

3.2.3 Smoke Management and Dispersion

The National Weather Service (NWS) forecast offices serving Florida provide twice-daily fire weather forecasts 365 days a year. Fire weather forecast offices are located at Mobile AL, and in FL at Tallahassee, Jacksonville, Melbourne, Ruskin (Tampa), Miami, and Key West. The fire weather forecast includes smoke management information and is available in the morning by 0700 hrs and in the afternoon by 1500 hrs.

The NWS also provides Smoke Management information via Spot Weather Forecasts. They are issued, as requested by land management agencies, for specific times and locations. See the Appendix, “National Weather Service Fire Weather Web Sites” for addresses and phone numbers. NWS contact information can also be found in the NWS, Florida Fire Weather Operations Plan. This document is available by accessing the FFS Weather section of our website and then the individual NWS office website, the Florida Operations Plan is the same statewide no matter which site you access.

To ensure optimum dispersal of smoke emissions during prescribed burns, the mixing layer must be deep enough and with sufficient transport wind speed to allow dilution and dispersal of emission concentrations. The DI describes the ability of the atmosphere to disperse emissions (See Table 1) and is the product of the mixing height (ft), stability index and transport wind speed (kts). The following dispersion information is included as part of the daily fire weather forecast: The morning forecast provides the expected maximum mixing height, transport wind speed and DI for the current day, nighttime and the following day. The afternoon forecast provides these parameters for the nighttime and following day. Prescribed burn managers who intend to ignite burns in the morning should consult their local Weather Service office to determine the anticipated dispersion at the time of ignition.

Table 1. Daytime Dispersion Index Categories and Interpretation

DISPERSION INDEX CATEGORY	DISPERSION CATEGORY INTERPRETATION
0 - 40	Possible smoke problems
40 - 70	Good Dispersion
70 >	Good Dispersion (control problems likely)

NOTE: Exercise caution when using the DI, with high transport wind and low mixing height or low transport wind and high mixing height which, although they combine to give an acceptable category, can cause smoke dispersion problems as well as potential control problems.

3.2.4 Suggested Smoke Screening Systems

Executing a Smoke Screening System

Prior to the selection of a smoke screening system for a particular burn, the burn manager should run through a check list of items that will help with the selection process. Following is a list of suggestions, all of which should be considered, and some of which should always be followed (designated by an *) and thus included in the written plan.

- **OBTAIN AND USE FIRE WEATHER FORECASTS*** – Fire weather forecasts contain information that is not commonly part of the general forecast provided in a radio/TV forecast. Smoke management information such as mixing height, transport winds, Dispersion Index should be part of the forecast you use. Don't rely on yesterday's forecast; get an updated one the day of the burn. Don't hesitate to ask for a spot weather forecast when you believe it is necessary for a successful burn.
- **DON'T BURN DURING POLLUTION ALERTS OR STAGNATE CONDITIONS*** – Do not add to the problem. Such conditions are often reported in the discussion section of the fire weather forecast.
- **COMPLY WITH ALL AIR POLLUTION CONTROL REGULATIONS*** – Know the rules that apply at the proposed burn site. Check with the FFS if unsure.
- **NOTIFY YOUR LOCAL FIRE CONTROL OFFICE, NEARBY RESIDENTS AND ADJACENT LAND OWNERS*** – This is common courtesy and can go a long way in reducing complaints; it is required in most areas. People need to know that your fire is not a wildfire.
- **USE A TEST FIRE TO CONFIRM BEHAVIOR OF BOTH THE FIRE AND ITS SMOKE***– Test fires are used to make certain observed fire behavior matches that in the burn prescription and is within acceptable limits. Also use the test fire to make sure the smoke is doing what you expect; which means a two minute 100 square foot fire is not acceptable. The test fire must be located within the burn unit, and in Florida is considered part of the authorized burn.
- **CONSIDER A BACK FIRE WHEN SMOKE IS AN ISSUE** – Back fires more completely consume the available fuel in the flame zone thereby minimizing smoldering combustion behind the flame front. However, back fires are not always the answer.
 - Back fires are slow, which means smoke production occurs over a longer period thereby extending the exposure time to changes in weather, particularly the mixing height which typically decreases rapidly in late afternoon, the result being limited smoke plume rise. To avoid this outcome, begin ignition earlier in the day before the mixing height attains its predicted maximum value. Although this can simply switch the limited smoke plume rise to early in the burn rather

than late in the burn, dispersion conditions should continue to improve with this option, rather than continue to deteriorate. To avoid these probabilities altogether, interior lines can be constructed which allow multiple lines of fire to be ignited at about the same time resulting in a much shorter burnout time, but at added cost. And if created by a tractor-plow, the berm can pose an insurmountable barrier to small fauna.

- Back fires produce lower fireline intensities and therefore do not develop as strong a convection column as other firing techniques. This weak convection column limits smoke rise keeping the plume closer to the ground. Other burning techniques can be used to increase the rate of heat release which experienced burners often use to loft smoke over smoke sensitive targets.
- BURN DURING THE MIDDLE OF THE DAY AND BE DONE WELL BEFORE SUNSET – Dispersion conditions are generally best during this time period.
- MOP-UP ALONG ROADS* – Start mop-up along roads as soon as practical to reduce any impact on visibility. Extinguish all stumps, snags and logs. Be particularly aggressive when roads are in or near drainages that may channel smoke at night.
- MONITOR YOUR SMOKE* – Patrol the burn perimeter as long as necessary post-burn and document where the smoke is/is not going.
- ALWAYS CHECK YOUR BURN FOR SMOKE AT DUSK* – If there is residual smoke, monitor all night unless there is very little; in which case, check again just before daylight the next morning.
- BECOME FAMILIAR WITH WHERE, AND AT WHAT TIME FOG OCCURS IN THE AREA* – Locate and mark fog-prone areas on your administrative map. When developing the burn prescription, check to see if the smoke plume might impact a fog-prone area. If so, make sure photos are taken to document the burn and smoke dispersion. If fog forms in the potential impact area the evening after a burn, monitor all roads in the area throughout the night. Be aware that conditions can deteriorate from relatively good visibility to zero visibility within a matter of minutes. Consider developing a smoke patrol plan with thresholds for specified levels of activation.
- HAVE AN EMERGENCY PLAN – Be prepared to extinguish the fire if the weather, fire behavior or smoke conditions are not within the ranges specified in the burn plan. Have warning signs available. Have contact information for local law enforcement.

KEEP IN MIND THAT THIS IS YOUR FIRE, AND THE SMOKE IS YOUR RESPONSIBILITY.

3.2.5 Florida Fire Management Information System (FMIS) Smoke Screening Tool

The primary components of the smoke modeling system are trajectories produced by HySplit (HYbrid Single-Particle Lagrangian Integrated Trajectory) first described by Draxler (1992) which has been used successfully in studies of volcanic ash plumes (Heffter and Stunder, 1993) and forest fires (Sapkota et al 2005). Downwind plume trajectories are created every hour at 3 levels above the burn site: surface, half of the mixed layer depth, and at the top of the mixed layer. Along each trajectory the perpendicular spreading of the plume is determined using a gaussian distribution following the methodology of VSmoke (Lavdas, 1996) with initial emissions calculated using CONSUME (Ottmar et al., 1993). A polygon representing the $300 \mu\text{g m}^{-3}$ ground level concentration of $\text{PM}_{2.5}$ is constructed and returned to FMIS for intersection with layers containing smoke sensitive features. The choice of a $\text{PM}_{2.5}$ concentration of $300 \mu\text{g m}^{-3}$ was chosen to provide a buffer zone around a concentration associated with visibility reductions of approximately three quarters of a mile, $500 \mu\text{g m}^{-3}$ (Therriault and Smith, 2001).

Because sugar cane fires typically produce much higher fireline intensities than prescribed underburns, the size and fall speeds of the particulate are adjusted. Following the work of Achtemeier (1998) initial vertical velocities and terminal velocities are assigned for a representative particle; this particle is then transported in a 2-dimensional (height-distance) plane using the forecast weather information to determine how far along the HySplit trajectories ash is likely to travel. The motivation for this approach over calculating an isopleth revolves around the lack of any definable ash concentration for use in defining an ash nuisance.

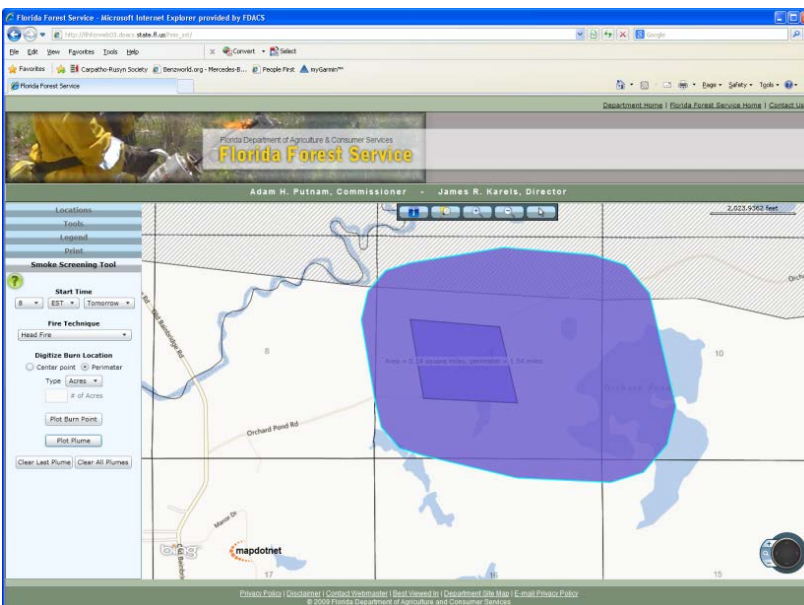

Fig. 1 - Smoke plume surface concentration above $300 \mu\text{g m}^{-3}$ using FFS Smoke Screening

concentrations reach the $300 \mu\text{g m}^{-3}$ threshold at the surface (See Fig.1), in other words from about your nose to the ground; they don't show the total height above the surface to

The smoke modeling component of FMIS provides FFS personnel a quick way to determine potential hazards from a planned burn as an integrated part of the authorization process. The modular nature of the system allows the same modeling component to be used by prescribed burners through an internet-based screening tool provided by the Florida Forest Service available at: http://flame.fl-dof.com/wildfire/tools_sst.html. Plumes produced by this smoke screening tool indicate only where the

which this threshold is exceeded. This web based application is user-friendly but does require the following information:

1. Start time
2. Firing technique e.g., head, back, pile etc.
3. Center point or outline of the perimeter
4. Type of burn – is it acreage or are you burning piles

At this point the user can have the model plot the plume where particulate matter concentrations exceed $300 \mu\text{g m}^{-3}$ at the surface. The plume is slightly buffered (enlarged footprint) to compensate for variations in the forecast wind direction. The advantage of this system is that it uses very detailed weather information, and sophisticated dispersion models to project the plume. The accuracy of this projection is better than that of simpler smoke screening tools, in part because the buffering process improves the accuracy of the forecasted impact area. The disadvantage of this system is that the weather information is only available for today and tomorrow, which means you cannot use this screening system to project the impact of a burn at a date further in the future.

3.2.6 Manual Smoke Screening System

Florida, like many other southern states has a mandatory requirement to use a smoke screening system for all burns classified as “certified” including piles. Although not a requirement for authorized burns conducted by non-certified burners (or certified burners who choose not to ask that a particular burn be ‘certified’) to pass a smoke screening process, the FFS uses the above smoke screening system prior to the issuance of any authorization on the day of, or day prior to the burn. If a burn manager does not choose to use the above computerized system, the screening system described below can instead be used.

Step 1. Plot Direction of the Smoke Plume

- A. Use maps on which the locations of smoke-sensitive areas can be identified. Plot the anticipated downwind smoke movement a distance of: 5 miles for grass fuels regardless of fire type (but see below); 10 miles for palmetto-gallberry fuels when using line-backing fires or spot fires; 20 miles for palmetto/gallberry fuels using line-heading fires; 30 miles for all logging debris fires; 5 miles for line backing fires in all other fuel types (but see below); and 10 miles for line-heading fires in all other fuel types. Plot the distance for 10 miles on all burns 250 acres or more. First locate the planned burn area on a map and draw a line representing the centerline of the path of the smoke plume (direction of transport wind) for the distance indicated. If the burn will last 3 or more hours, draw another line showing predicted wind direction at completion of the burn.

- B. To allow for horizontal dispersion of smoke as well as shifts in wind direction, draw two other lines from the fire at an angle of 30 degrees from the centerline(s) of observed wind direction (45 degrees if forecast wind direction used). If fire is represented as a spot, draw as in figure A. If larger, draw as in figure B. The result is your probable daytime smoke impact area.

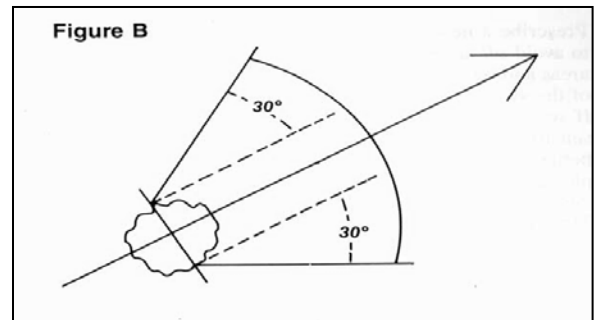
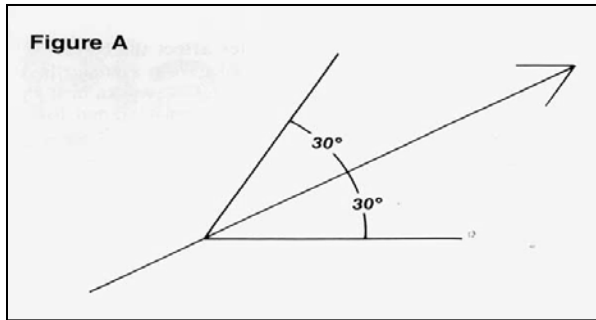

- C. Now go down-drainage for one-half the distance used above, but do not spread out except to cover valleys and bottoms. The result is your probable nighttime impact area, providing the burn will be completed at least 3 hours before sunset, and providing the forecast night winds are light and variable.

Step 2. Identify Smoke-Sensitive Areas

Identify and mark any smoke-sensitive areas (such as airports, highways, communities, recreation areas, schools, hospitals, and factories) within the impact zone plotted in step 1. These areas are potential targets for smoke from your burn.

- A. If **no** potential targets are found, proceed with the burn as prescribed.
- B. If the area to be burned contains organic soils that are likely to ignite, do not burn.
- C. If any targets are found in the impact area, continue this screening system.

Step 3. Identify Critical Smoke-Sensitive Areas(SSA)

- A. Critical SSAs are:
 1. Those that already have an air pollution or visibility problem.
 2. Those within the probable smoke impact area as determined below. If the distance determined in step 1 was:
 - a. 5 miles, any SSA within 1/2 mile is critical, both downwind and down-drainage.
 - b. 10 miles, any SSA within 1 mile is critical.
 - c. 20 miles, any SSA within 2 miles is critical.
 - d. 30 miles, any SSA within 3 miles is critical

- B. If any critical SSAs are located, **Do Not Burn** under present prescription!
 - 1. Prescribe a new wind direction that will avoid such targets and return to the beginning of this screening system, or
 - 2. If smoke-sensitive area is in last half of distance criteria, reduce the size of the area to be burned by approximately one half, complete burn at least 3 hours before sunset, and aggressively mopup and monitor, or
 - 3. Use an alternative other than fire.
- C. If no critical smoke-sensitive areas are found, or criteria B1 or B2 is met, continue the screening system.

Step 4. Determine Fuel Type

The smoke produced may vary greatly by type, amount, and condition of fuel consumed.

- A. From the list below determine which broad type best fits your fuel.
 - 1. Grass (with pine overstory)
 - 2. Light brush
 - 3. Pine needle litter
 - 4. Palemetto-gallberry
 - 5. Windrowed logging debris
 - 6. Scattered logging debris or small dry piles
- B. Review fuel categories or combinations.
 - 1. If the fuel type is described by one of the above categories, continue.
 - 2. If your fuel type is not comparable to any of the above, pick the fuel type for which fire behavior and smoke production most nearly compare with yours and proceed with **EXTREME CAUTION** on the first few burns.
- C. If the fuel type is windrowed logging debris, and you have identified SSAs, **Do Not Burn** under present prescription. Smoke production is great and residual smoldering can last for weeks.
 - 1. Prescribe a new wind direction to avoid **all** SSAs and return to the beginning of the system.
 - 2. If you cannot avoid all SSAs, you will need a better procedure than this simple screening system. Refer to the ***Southern Forestry Smoke Management Guidebook*** (Southern Forest Fire Laboratory staff 1976) or use ***PRESMOK***; copies are available from the Southern Forest Fire Laboratory.
- D. If the fuel type is scattered logging debris or small, essentially dirt-free, dry piles, the following conditions should be met:
 - 1. Size of area to burn less than 100 acres.
 - 2. No major highways within 5 miles down drainage.
 - 3. No other smoke-sensitive areas within 3 miles down drainage.
 - 4. If relative humidity is predicted to stay below 80 percent and surface winds above 4 mph all night, the distances in 2 and 3 above can be cut in half.

- E. If your comparable fuel type is one listed in 4A above, determine your total per-acre fuel loading. See below or *Southern Forestry Smoke Management Guidebook* for tables to assist you.
1. If less than 10 tons per acre, continue. Generally, the **total** fuel loading will be less than 10 tons in the fuel types listed below when age of rough is:
 - a. Grass (with Longleaf pine overstory), any age. Also wheat fields and other agricultural burns.
 - b. Light brush, 7 years old or less (10 years if basal area is under 100 square feet per acre).
 - c. Loblolly pine with
 - 1.) palmetto-gallberry understory, 7 years or less if basal area is less than 150 square feet per acre.
 - 2.) little or no understory, 15 years or less if basal area is under 150 square feet per acre.
 - d. Slash pine with
 - 1.) palmetto-gallberry understory, 5 years or less if basal area is less than 150 square feet per acre.
 - 2.) little or no understory, 8 years or less if basal area is under 150 square feet per acre.
 2. If greater than 10 tons per acre, refer to the Southern Forestry Smoke Management Guidebook or double the distance determined in step 1A. Use 1½ times the distance if close to 10 tons.

Step 5. Minimize Risk

To meet your smoke management obligations when any SSA may be affected by your burn, you **must meet all** of the following criteria to minimize any possible adverse effects.

- Height of mixing layer (mixing height) is **1,650** feet (500 meters) or greater.
- Transport windspeed is 9 mph (4 meters per second) or greater.
- Background visibility is at least 5 miles within the plotted area.
- If rough is older than 2 years, use a backing fire. If burn can be completed 3 hours before sunset, or if no SSAs are located in the first half of the impact area, other firing techniques can be used.
- Promptly mopup and monitor to minimize smoke hazards.
- If a SSA is in the overlapping trajectory of two smoke plumes, it should be 1 mile from either source (2 miles if one is from logging debris).
- For night burns, backing fires with surface windspeed greater than 4 mph and relative humidity under 80 percent should be prescribed.
- If it appears that stumps, snags, or logs may cause a residual smoke problem, take steps to keep them from burning. If they do ignite, extinguish them.

- Daytime DI value between 41 and 60 is adequate for small fires and low levels of burning activity. As either size of individual fires or level of burning activity increases, the DI value should also increase.

Many variables affect the behavior and resulting smoke from a prescribed burn. The above system works best in flat terrain and was not designed for mountainous country. It does not attempt to consider all the variables: it can only offer broad guidelines. If your prescribed fire complies with all conditions in these five steps, you should be able to safely burn without causing a smoke problem. If you have any marginal answers, areas that are especially sensitive to smoke, heavy fuel loadings or wet fuels, use the computerized system on the Florida Forest Service web page, found under “Tools & Downloads.” The plume is slightly buffered to take into consideration variations in wind direction. You must make the final judgment.

Caution: Be Sure To Check the DI to Make Certain Atmospheric Conditions Are Conducive To Good Smoke Dispersal!

3.2.7 Manual Screening System for Managing Smoke in the Wildland Urban Interface (WUI)

The WUI Smoke Screening System

It is important to differentiate between burns conducted in areas where they will have little to no impact on the local population, and those conducted in close proximity to what is typically referred to as the Wildland Urban Interface (WUI). Burns that are conducted in the WUI require greater planning, more support, and major public relations efforts that keep the local population informed about the who, what, when, where and why of the burn. The following screening system was developed specifically for the WUI (Wade and Mobley, 2007). We do not claim it is foolproof, but we believe it will eliminate most issues associated with burning units smaller than 50 acres. This screening system cuts back on the burn window that Certified Prescribed Burn Managers may use in Florida. CPBMs should review the system and make decisions concerning when to cut off their burn based on their experience and the sensitivity of the area of concern.

This system has five steps. The flowchart (**Fig. 2**) on page 28 diagrams the process.

- Step 1 – Plot Distance and Direction of Probable Smoke Plume and Residual Smoke
- Step 2 – Identify SSAs
- Step 3 – Deal With SSAs Within the First $\frac{1}{4}$ of the Downwind and Down-drainage Impact distance
- Step 4 – Deal With SSAs Within the Last $\frac{3}{4}$ of the Downwind and Down-drainage Impact distance
- Step 5 – Interpret Screening System Results

Step 1 - Plot Distance and Direction of Probable Smoke Plume

Step 1A

Use a map on which locations of all SSAs can be identified and plot footprint of the planned burn. Then draw another line around the burn 500 feet out from the edge of the burn area. This 500-foot buffer zone indicates the area that is likely to be impacted regardless of wind direction. If the intended burn unit is larger than 50 acres, divide it into subunits that are about 50 acres or less in size. **Go to Step 1B.**

Step 1B

Choose the DI under which you plan to burn. Lower DIs (<41) are not recommended because of poor smoke dispersion and DI's above 70 are not recommended because of the likelihood of fire control problems. Note that in Florida, the DI threshold for red flag conditions is 75. Consider the DI chosen to be a tentative selection at this point. Use the tentatively selected DI in Table 2 below to determine the maximum distance that smoke is likely to be a problem based on the fuel category and firing technique chosen. Visible smoke may be present for this distance, although it can be smelled at much greater distances. **Go to Step 1C.**

Fig. 2 - Flowchart of the Wildland/Urban Interface (WUI) Smoke Screening System

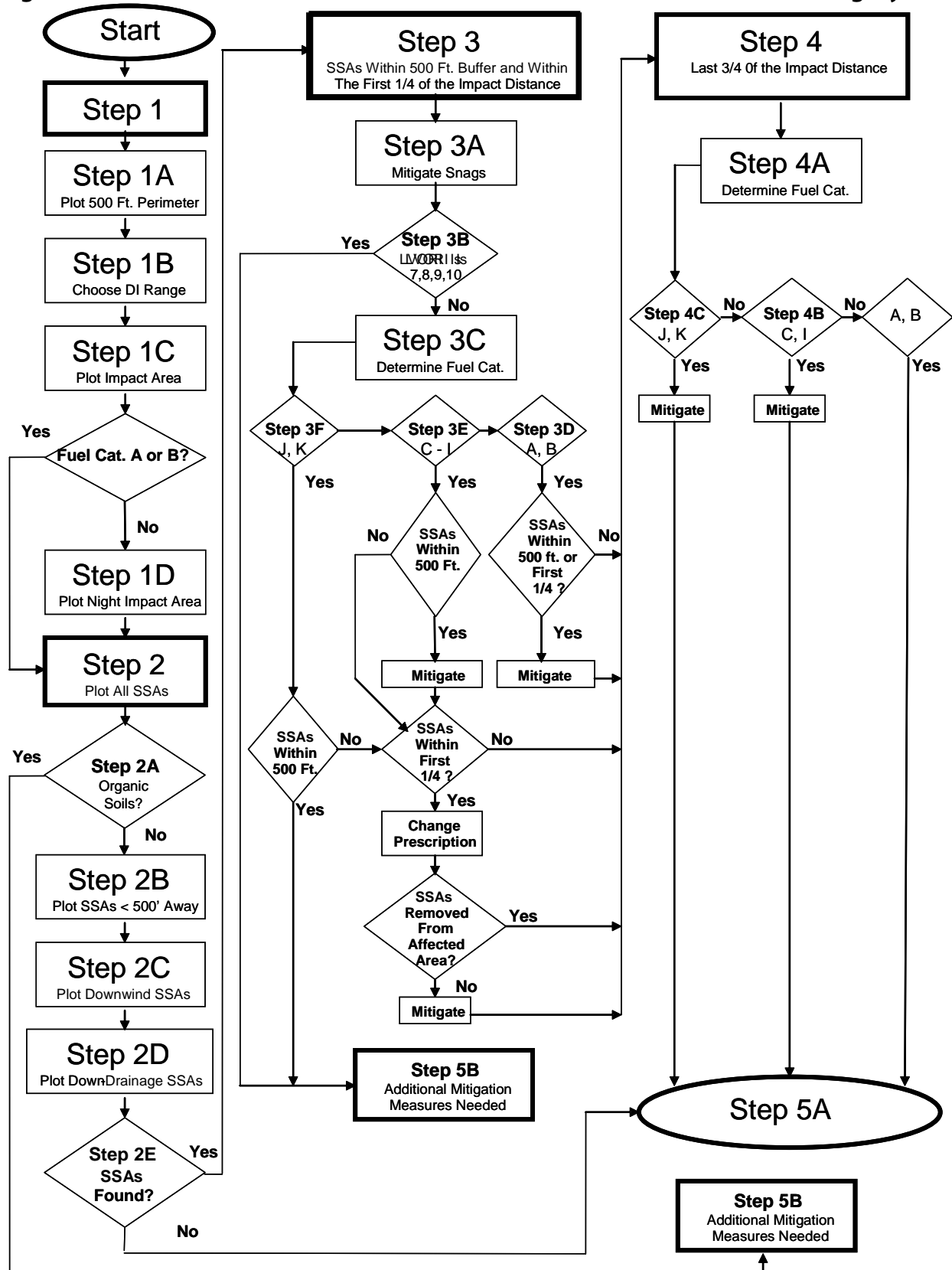
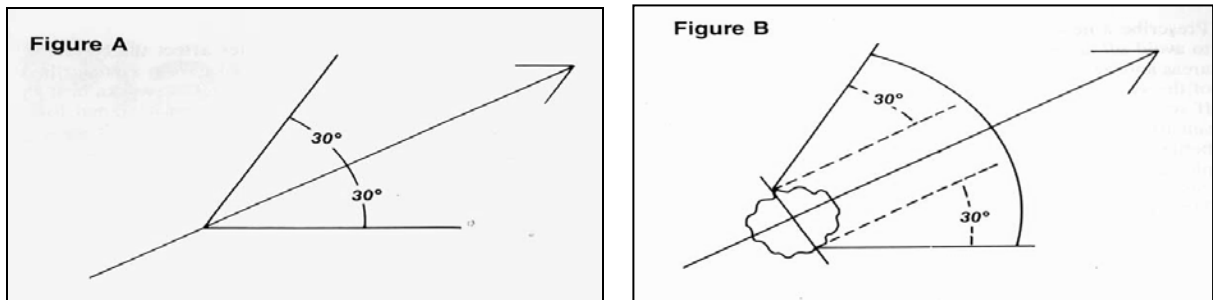

Table 2 - Distance of Probable Smoke Impact From Burns < 50 Acres in Size					
Fuel Category		Firing Technique	Dispersion Index		
			41-50	51-60	61-70
Impact Distance in Miles					
A	Grass, Light Understory (Less Than 2-yr Rough) With No Humus Layer	Any Firing Technique	0.75	0.5	0.25
B	Non-woody Marsh Fuels - Rush, Cattail or Sawgrass	Any Firing Technique	1.5	1.25	1
C	Palmetto/Gallberry or Wax Myrtle Understory Regardless of Height	Backing Fire	1.25	1	0.75
D+, \$	Palmetto/Gallberry or Wax Myrtle Understory Regardless of Height	Head, Flank or Spot Fires	4	3	2
E	Any Other Native Understory Fuel Type Regardless of Height	Backing Fire	1	0.75	0.5
F	Any Other Native Understory Fuel Type Under 3 Feet High	Head, Flank or Spot Fires	1.5	1	0.75
G	Any Other Native Understory Fuel Type Over 3 Feet High	Head, Flank or Spot Fires	2	1.5	1
H+\$	Melaleuca	Backing, Flank or Spot Fires	3	2	1
I	Exotic Fuelbeds Without Much Understory Such as Casuarina	Any Firing Technique	2.5	2	1.5
J+	Scattered Logging Debris	Any Firing Technique	2.5	1.5	1
K+	Small Dry Piles	Any Firing Technique	3	2	1.5
L*	Large, Wet Piled Debris Or Windrows	Using Any Firing Technique	Do Not Burn		
+	Firing should be completed at least 2 hours before sunset because dispersion will rapidly deteriorate at dusk.				
\$	Line headfires in 4-5 ft high palmetto, gallberry, wax myrtle or melaleuca are very likely to result in severe overstory crown scorch.				
*	Windrows are the most polluting of all southern fuel types. They contain large fuels, dirt, and are compact which makes them very slow to dry once wet, and severely limit the amount of oxygen available for the combustion process. Dirt in piles or windrows will drastically increase the amount of smoke produced and such piles can smolder for weeks. To burn under this screening system, any large piles of debris or windrows, when dry, will have to be reconfigured into small round piles with any stumps removed or fireproofed.				

Step 1C

Draw a line representing the centerline of the path of the smoke plume (transport wind direction) from the burn. Draw this line for the length of the impact distance determined from Table 2. To allow for horizontal dispersion of smoke as well as shifts in wind direction, draw two additional lines out the same distance from the burn unit at an angle of 30 degrees from the centerline of the transport wind direction. Connect the ends of the arc (Figures A and B). Note that the transport wind direction and surface wind direction may differ on the day of the burn (e.g.; seabreeze). In this case, plan for the change in smoke plume direction. When burning on a seabreeze, keep in mind that once the smoke plume is over water, it will likely drop to the surface and be blown back inland; the firing technique and pattern used should thus assure that the plume has dissipated by the time it is blown back across the shoreline so that people will not be adversely impacted. When rechecking winds on the day of the burn, if forecast or actual surface winds are light and variable, replot the impact area using a 45-degree angle.

If the fire is represented as a spot on the map you are using, draw as in Figure A. If larger, draw as in Figure B. The result is the probable daytime smoke impact area. The heaviest concentration will be along the centerline.



The blue lines in **Fig. 3** show the application of Step 1C (**Fig. 2**) to an example area. If grass, non-woody marsh fuels, or less than a 2-yr rough (fuel categories A and B), **Go to Step 2**, otherwise **Go to Step 1D**.

Step 1D

Next, go down-drainage the same distance determined from Table 2. Draw a narrow area covering only the “bottom” or width of the drainage area. This area may, or may not, be within the daytime smoke impact area.

Fig. 3 Predicted footprint of smoke plume.

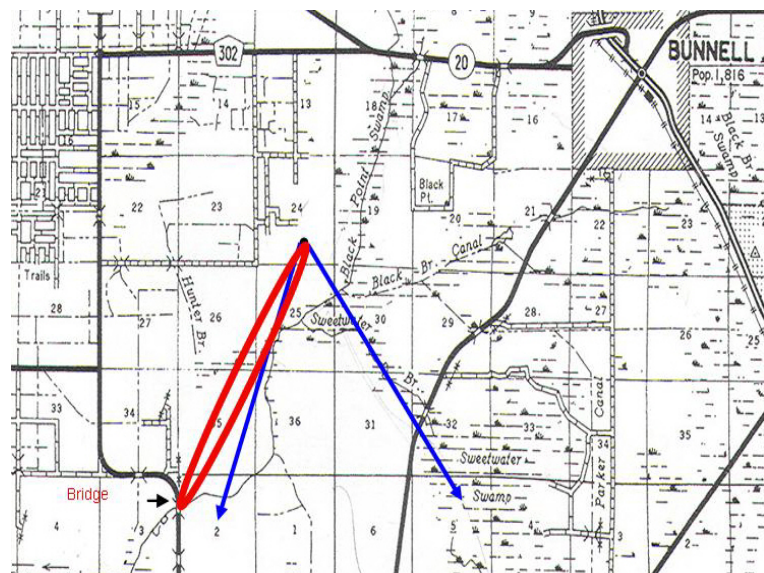

The result is your probable nighttime impact area due to the residual (smoldering) smoke produced. Note the area encompassed by the red line in **Fig. 3**; the graphics used in this figure suggest that residual smoke not entrained into the convection column will travel in a straight line from the fire to the bridge, but in reality it will follow the stream down-drainage meandering in and out of the daytime smoke impact area. Complete this step even if you plan to have the burn completely mopped up (OUT) at least 2 hours before dusk. Then, if for some reason residual smoke is present at dusk, you will know where it is likely to concentrate. Go to Step 2.

Step 2 - Identify Smoke Sensitive Areas

Step 2A

If the area to be burned contains organic soils that are likely to ignite, **Go to Step 5B**, otherwise **Go to Step 2B**.

Step 2B

Identify and mark any Smoke Sensitive Areas (SSAs) within 500 feet of the perimeter of the planned burn, regardless of direction from the fire as determined in Step 1A above. List these in your written prescription. Coordinate contact list with Public Relations. **Go to Step 2C**.

Step 2C

Identify and list any SSAs located within the probable downwind impact area determined in Step 1C above. **Go to Step 2D**.

Step 2D

Identify and list any SSAs located within the down-drainage impact area determined in Step 1D. **Go to Step 2E**.

Step 2E

If any SSAs were identified in 2B thru 2D, mitigation is necessary as suggested in Steps 3 and 4. **Go to Step 3**.

If no SSAs are found, as described in Steps 2A through 2D, then it is not likely you will have a smoke management problem. **Go to Step 5A**.

Step 3 - Dealing With SSAs Within the 500ft Buffer and First ¼ of the Impact Distance

Step 3A

Consider felling snags. If their retention is spelled out in the land management plan, follow standard procedures to keep them from igniting. **Go to Step 3B**.

Step 3B

If the predicted or actual LVORI is 7 or above, **Go to Step 5B.**

Step 3C

For Fuel Categories A-I, if any homes are within the 500 foot buffer, each homeowner must be personally contacted and informed that their home will likely be impacted by smoke; their response (e.g.; severe respiratory problem or undue fear that their home will be lost) should guide what actions are taken (Include in the Public Relations plan).

Use the same Fuel Category selected in Step 1B (Table 2) and go to the step indicated below for that category.

- Fuel Category A or B - **Go to Step 3D.**
- Fuel Category C, D, E, F, G, H or I - **Go to Step 3E.**
- Fuel Category J or K - **Go to Step 3F.**

Step 3D - Fuel Categories A and B

If no SSAs are within the 500 ft buffer zone or first $\frac{1}{4}$ of the downwind smoke impact distance, **Go to Step 4.**

If any SSAs are within the buffer zone or first $\frac{1}{4}$ of the downwind smoke impact distance, a smoke problem resulting from the smoke plume is a distinct possibility. First, try changing the wind direction or increasing the DI to minimize the number of SSAs within the smoke impact area.

If changing the wind direction or increasing the DI removes all SSAs from the buffer and first $\frac{1}{4}$ of the downwind smoke impact distance, **Go to Step 4.** Otherwise, if a SSA within the buffer zone or first $\frac{1}{4}$ of the impact distance is unavoidable, you must mitigate the problem. Either mop up the burn completely (all smokes out) at least 1 hour before sunset, or complete active burning at least 3 hours before sunset under one or more of the conditions listed below, and mop up until dusk:

- Dispersion index above 50
- Mixing height above 2,500 ft
- Surface winds less than 8 mph and transport wind speeds greater than 15 mph
- If the SSA is a road, mitigate by controlling or rerouting traffic during the burn

Continue by **Going to Step 4.**

Step 3E - Fuel Categories C, D, E, F, G, H or I

If an SSA is within 500 feet of the fire perimeter, regardless of the direction from the fire, divide the unit into 2 or more subunits, the smallest of which faces the SSA. An exception to creation of subunits can occur where smoke corridors are already established by county ordinance.

- The smallest subunit should have a depth such that the distance from the closest SSA to the back of the subunit is at least 500 feet deep on the edge of the burn facing the SSA and bounded by hard (plowed) lines or drainage ditches containing standing water. The burn manager may select a shorter distance in specific situations. If the SSA is a road, closing the road during the burn removes this distance restriction. If the SSAs are homes, every homeowner must agree to the reduced distance with the full understanding that their residence could be impacted by drift smoke. In no instance should a smoke plume engulf an occupied residence.
- Burn this smallest subunit first during the middle of the day, preferably when steady eye-level winds equal to or greater than 2mph are blowing away from the SSA. If you desire to burn this subunit when eye-level winds are blowing toward the SSAs, consider weather conditions and a firing technique that will facilitate lofting the smoke plume over the SSAs.
- If a SSA is down-drainage, make sure the subunit can be burned and completely mopped up (out) by dusk. This may require breaking the subunit into smaller (about 5-acre) blocks.
- If the SSA is a road, either mitigate by rerouting traffic during the burn or have flaggers strategically stationed. Be ready to extinguish the fire if necessary.

Once the smallest subunit is burned out, if no other SSAs are within 500 feet of the burn, address any SSAs within the first $\frac{1}{4}$ of the impact area of all the other subunits.

When multiple SSAs are within 500 feet of the burn unit on more than 1 side, your options are further constrained. If a road, control traffic flow; if homes, contact every resident and make sure they understand their residence may be impacted by residual smoke. Under no circumstances should a residence be directly impacted by the plume, or impacted by residual smoke throughout the night. If you are not sure that ALL smoke will be pulled away from the SSAs as the remaining subunits are burned, divide into additional subunits.

If no SSAs are within the first $\frac{1}{4}$ of the downwind smoke impact distance, **Go to Step 4.**

If any SSAs are within the first $\frac{1}{4}$ of the downwind smoke impact distance, a smoke problem resulting from the smoke plume is a distinct possibility. Change prescribed wind direction or increase DI to minimize the number of SSAs that lie within the first $\frac{1}{4}$ of the downwind smoke impact distance.

If changing the prescribed wind direction or increasing the DI removes all SSAs from the first $\frac{1}{4}$ of the downwind smoke impact distance impact area, **Go to Step 4.** Otherwise, if an SSA within the first $\frac{1}{4}$ of the impact distance is unavoidable, you must mitigate the problem. Burn and mop up completely (all smokes out) at least 1 hour before sunset or complete active burning at least 3 hours before sunset under one or more of the conditions listed below and mop up until dusk.

- Dispersion index above 50
- Divide unit into roughly 5-acre blocks and burn them separately
- Surface winds less than 8 mph and transport wind speeds above 15 mph
- Use a backing fire and complete burn at least 2 hours before sunset. Begin mop-up soon after the flame front has passed.
- Mixing height above 2,500 feet
- Keep stumps from igniting
- If the SSA is a road, mitigate by controlling or rerouting traffic during the burn

Continue by **Going to Step 4.**

Step 3F - Fuel Categories J and K

If any SSAs are within the 500-foot buffer zone, **Go to Step 5B.**

If no SSAs are within the first $\frac{1}{4}$ of the downwind smoke impact distance, **Go to Step 4.**

If any SSAs are within the first $\frac{1}{4}$ of the downwind smoke Impact distance, a smoke problem resulting from the smoke plume is a distinct possibility. Change prescribed wind direction or increase DI to minimize the number of SSAs that lie within the first $\frac{1}{4}$ of the downwind smoke Impact distance.

If changing the prescribed wind direction or increasing the DI removes all SSAs from the first $\frac{1}{4}$ of the downwind smoke Impact distance, then **Go to Step 4.** Otherwise, if an SSA within the first $\frac{1}{4}$ of the Impact distance is unavoidable, you must mitigate the problem. Burn and mop up completely (all smokes out) at least 1 hour before sunset. The following conditions will facilitate smoke dispersal:

- Dispersion Index above 50
- Keep stumps from igniting
- Reduce the size of the unit into roughly 5-acre blocks and burn them separately
- Burn when the mixing height is above 2,500 feet
- Surface winds less than 8 mph and transport wind speeds greater than 15 mph
- If SSA is a road, control or reroute traffic during the burn

Continue by **Going to Step 4.**

Step 4 - Dealing With Smoke Sensitive Areas Within the Last $\frac{3}{4}$ of the Impact Distance

Step 4A

Select the same Fuel Category used in Step 3. Selections are grouped by Fuel Category as follows:

- Fuel Category A or B - **Go to Step 5A**
- Fuel Category C, D, E, F, G, H or I - **Go to Step 4B**
- Fuel Category J or K - **Go to Step 4C**

Step 4B - Fuel Category C, D, E, F, G, H or I

Either:

- Complete firing at least 3 hours before sunset and mopup a minimum of 500 ft in from the downwind side.
- Use a back fire and completely mop up of the burn at least 1 hour before sunset. Begin mopup soon after the flame front has passed and continue until dusk.

If residual smoke is present at dusk, monitor all night and be prepared to act if a roadway is impacted.

Continue by **Going to Step 5A.**

Step 4C - Fuel Categories J or K

If no interstate or major highways are within 2 miles down-drainage consider the list of potential measures below. Implement as many as practical to mitigate potential smoke problems.

- Burn when Dispersion Index is above 50
- Reduce the size of the area to be burned
- Complete firing at least 3 hours before sunset
- Mop up as needed
- Burn when surface winds are less than 8 mph and transport wind speeds are greater than 15 mph
- Monitor smoke all night and be prepared to act if a roadway is impacted
- Keep stumps from igniting
- Burn when mixing height is above 2,500 feet

If interstate or major highways are within 2 miles down-drainage, divide the unit into subunits.

Continue by **Going to Step 5A.**

Step 5: Interpreting Screening System Results

Step 5A – All Requirements Met

If all the requirements in the smoke screening system have been met to this point, it is not likely that the prescribed fire will result in a smoke problem if the maximum project size is less than 50 acres. Keep in mind that as the DI class under which the burn is conducted

increases, fire intensity and suppression become more challenging. For projects greater than 50 acres, you must subdivide the unit into blocks of about 50 acres or less in size if you wish to use this WUI screening system.

If you proceed and a smoke problem is encountered, please notify others of the problem you encountered (e.g.; your prescribed fire council) and get word back to the Southern Research Station, Disturbance Work Unit, Smoke Management Team located in Athens, Georgia, at the following web address:

<http://www.srs.fs.usda.gov/forestdisturbance/>

so that the situation can be examined and changes to the screening system can be made as appropriate.

Step 5B – All Requirements Not Met

If all the smoke screening system requirements have not been met, consider the following:

- Do not burn. Use a mechanical, chemical or biotic alternative instead.
- Change the prescription to meet the requirements.
- Reduce the burn unit size to roughly 2-acre blocks, burn with low surface winds, and mop-up completely by dark.

There may be rare situations where a proposed burn will not pass any smoke screening system under the best dispersion conditions, but the use of fire is still the preferred alternative. In such cases, the burn manager should take all the extra steps listed below and then proceed with extreme caution:

- All homeowners within the potential impact area agree to tolerate any temporary inconveniences associated with the intended burn.
- Local law enforcement and government officials are kept informed and do not oppose the burn.
- All homeowners are contacted within several weeks of the burn and informed of the planned burn date, anticipated ignition time, burn duration, and mop-up time. Homeowners should be given a website where any schedule changes will be posted.
- In the above situations, it is still strongly recommended that:
 - The burn be completely mopped up and declared out before leaving
 - If residual smoke is present at dusk, monitor it throughout the night

CHAPTER 4. Public Relations and Image Management

4.1 PUBLIC EDUCATION AND AWARENESS

The Florida Forest Service, through the Florida Prescribed Fire Councils, including state and federal partners, will continue to explain and promote the importance of fire for ecosystem management, the implications to public health and safety, and the goals of the Certified Florida Smoke Management Program. Florida has one of the oldest Certified Smoke Management Plans in the country. The program was certified by EPA in 1999. The public relations program will continue to use posters, billboards, videos, and pamphlets, as well as news releases and public presentations to highlight actual burn events. Fire results and air quality impacts or mitigation efforts will also be posted. A key cooperater in this process will continue to be the FL DEP Division of Air.

4.2 SURVEILLANCE AND ENFORCEMENT

Prescribed burning in Florida is conducted under the direct supervision of either a certified or non-certified burn manager (both broadcast and piles). Only a Certified Burn Manager can conduct a certified burn in Florida and if he or she chooses to do so, the burn is required to include a smoke screening plan as part of the written burn prescription. FFS will screen for impacts to FFS designated SSAs regardless of burner certification. If the screening system indicates a SSA might be impacted, a local supervisor will review the proposed burn and set specific criteria under which the planned burn may proceed. These criteria can be found in Florida's Administrative Code (FAC) and in Florida Statutes. Violations of the Plan will result in the FFS turning the case over to the Florida Department of Agriculture's Office of Agricultural Law Enforcement. In addition, if the burner is certified, the violations will carry an assessment of points in accordance with the appropriate Point Assessment Table, (Certified Prescribed Burn Manager or Certified Pile Burner). Certified burners may not accumulate more than 14 points in a two year period. If they exceed this number, Florida Administrative Code requires that they lose their certification.

The SMP is an evolving document routinely evaluated by the FFS with input from the Florida Department of Environmental Protection's Division of Air. Issues that arise concerning smoke management are discussed by these two agencies and the SMP amended as necessary to resolve them.

4.3 OPTIONAL AIR QUALITY PROTECTION

Agencies may establish specific, more stringent protection criteria for special protection areas such as Class 1 areas and wildland urban interface areas. These additional requirements, at a minimum, must be documented in local ordinances/legislation and applicable environmental documents, and may be added to this plan as addenda when formalized.

GLOSSARY

Air Quality Manager – The regulatory agency person responsible for managing the air quality protection program for a State, local or tribal government.

Air Quality – Characteristics of ambient air as indicated by concentrations of the six air pollutants (called criteria air pollutants) for which national standards have been established.

Air Quality Related Values (AQRV) – Those special attributes of a Class I area that deterioration of air quality may adversely affect. Some examples of AQRV include: flora and fauna, water, visibility, and odor.

Ambient Air – That portion of the atmosphere, external to buildings, to which the general public has access.

Attainment area — A geographic area in which levels of a criteria air pollutant meet the health-based primary standard (NAAQS) for the pollutant. An area may have an acceptable level for one criteria air pollutant, but unacceptable levels for others. Thus, an area could be both attainment and non-attainment at the same time. Attainment areas are defined using pollutant limits set by the EPA.

Certified Prescribed Burn Manager – An individual who successfully completes the certification program of the FFS as outlined in subparagraphs 5I-2.006(2)(e)1. through 5., F.A.C., and possesses a valid certification number.

Certified Pile Burner – An individual who successfully completes the certification program of the Division as outlined in subparagraphs 5I-2.006(8)(c)1. through 5., F.A.C., and possesses a valid certification number.

Class 1 Area – An area set aside under the Clean Air Act (CAA) to receive the most stringent protection from air quality degradation. Class I areas are (1) international parks, (2) federal wilderness areas that exceed 5,000 acres in size, (3) national memorial parks that exceed 5,000 acres in size, and (4) national parks that exceed 6,000 acres and were in existence prior to the 1977 CAA Amendments. The extent of a Class I area includes any subsequent change in boundaries.

Clean Air Act (CAA) – The Clean Air Act of 1970 is a federal law intended to reduce air pollution and protect air quality. The act—which underwent major revisions in 1990 and 2003—deals with ambient air pollution (that which is present in the open air) as well as source-specific air pollution (that which can be traced to identifiable sources, such as factories and automobiles). The Clean Air Act sets standards for air quality that limit the amount of various pollutants to specified levels. The Clean Air Act also sets deadlines for governments and industries to meet the standards. The federal Environmental Protection Agency (EPA) is ultimately responsible for establishing standards and enforcing the Clean Air Act, although much of the daily business of fighting air pollution takes place at the state and local levels.

Combustion – For purposes of this SMP, the pyrolysis (or rapid oxidation) of fuels such as coal, oil, gas, and wood which produce CO₂, water vapor and criteria NAAQS pollutants, such as sulfur dioxide, nitrogen oxides, and particulates (PM₁₀ & PM_{2.5}).

Complexity – An adjective used to rate the potential difficulty of a prescribed burn by analyzing the cumulative elements that may be involved in the burn such as safety, threats to boundaries, fuel types, values to be protected, organization needed, air quality values to be protected, etc. Complexity is usually rated as Low, Moderate, or High.

Criteria Air Pollutants – EPA regulated compounds for which NAAQS have been established. They are: particulate matter (PM), carbon monoxide (CO), sulfur dioxide (SO₂), ozone (O₃), nitrogen oxides (NO_x), and lead (Pb). Several are combustion products of all fires, wild and prescribed.

Dispersion Index (DI) – is a numerical index from 0 to infinity supplied daily by the National Weather Service (NWS) that estimates the atmosphere's capacity to distribute particles and gases emitted by a wildland fire of any type. The Dispersion index has two relative scales, one for day and one for night.

Emission – A substance discharged into the air from a mobile source (e.g. vehicle), stationary source (e.g. industry), or area sources (e.g. prescribed burning or agricultural burning).

Equilibrium Moisture Content – The moisture content a fuel will reach and remain at when exposed to constant temperature and humidity for an infinite length of time. EMC determines the amount of water vapor that a specific piece of wood can hold at a given temperature and humidity. As temperature and humidity are constantly changing the EMC is also known as the dynamic equilibrium moisture content.

Exceptional Event – Exceptional events are events for which the normal planning and regulatory process established by the Clean Air Act (CAA) are not appropriate.

Fire Management Plan (FMP) – A strategic plan that defines a program to manage wild and prescribed fires to meet management objectives outlined in an approved land use plan. The FMP is supplemented by operational procedures such as preparedness plans, burn plans, and prevention plans.

Fire Dependent Ecosystem – A community of plants and animals that must experience recurring disturbance by fire to ensure full ecosystem function including plant succession, vegetative structure and composition, fuel loading, and nutrient cycling.

Fuel – Live and dead vegetative matter such as grass, trees, shrubs, limbs, branches, duff, and stumps.

Haze – An atmospheric aerosol of sufficient concentration to be visible. The particles are too small to see individually, but reduce visual range by scattering and absorbing light.

IMPROVE – An acronym for Interagency Monitoring of Protected Visual Environments, a program that uses air monitors in or near Class I areas to measure visibility-reducing pollutants including sulfates, nitrates, organic and elemental carbon, and PM₁₀.

Inversion – A layer in the atmosphere where the temperature increases with altitude. Inversions occur within several hundred feet of the ground almost every night throughout Florida. See also Temperature Inversion.

Land Use Plan – A broad-scale, long-range plan (e.g., forest plan, refuge plan, or resource management plan) that identifies the scope of actions and goals for land and resources administered by a land owner/manager.

Monitoring (monitor) – In the context of this document, measurement of air pollution is referred to as monitoring. EPA, state and local agencies measure the types and amounts of pollutants in the ambient air.

National Environmental Policy Act (NEPA) – Establishes procedures that Federal agencies must follow in making decisions that may impact the environment. Procedures include evaluation of environmental effects of proposed actions, alternatives to proposed actions, and involvement of the public and cooperating agencies.

National Ambient Air Quality Standards (NAAQS) – Standards set by EPA for maximum acceptable concentrations of “criteria” pollutants in the ambient air. Standards are established to protect public health with an adequate margin of safety (primary standard), and to protect public welfare (secondary standard) from any known or anticipated adverse effects of such pollutants (e.g., visibility impairment, soiling, materials damage, etc.).

Nonattainment area – A geographic area in which the level of a criteria air pollutant is higher than the level allowed by federal standards. An estimated 60% of Americans live in nonattainment areas.

Nuisance Smoke – Amounts of smoke in the ambient air that interfere with a right or privilege common to the public, including the use or enjoyment of public or private resources.

Ozone(O₃) – A gas consisting of three oxygen atoms. Ground-level ozone is a product of chemical reactions between nitrogen oxides (NO_x) which are produced by burning coal, gasoline and other fuels, and volatile organic compounds (VOC) which come from chemical solvents, paints, hair sprays, etc. in the presence of sunlight. Ozone is the main component of smog.

Particulate Matter (PM) – A mixture of very small particles suspended in the atmosphere (except uncombined water), which exist as solids or liquids at standard conditions (e.g., dust, smoke, mist, fumes, or smog).

PM₁₀ – Particles with an aerodynamic diameter less than or equal to a nominal 10 micrometers (including PM_{2.5}). Concentrations in the air are measured as micrograms per cubic meter of air (µg/m³).

PM_{2.5} – Particles with an aerodynamic diameter less than or equal to a nominal 2.5 micrometers. Concentrations in the air are measured as micrograms per cubic meter of air (µg/m³).

Prescribed Fire – The controlled application of fire to naturally occurring vegetative fuels under specified environmental conditions while following appropriate measures to confine the fire to a predetermined area to accomplish planned natural resource management objectives.

Prescription – A written plan establishing conditions and methods for conducting a prescribed burn and is a requirement for a certified burn.

Project Plan – A strategic plan for accomplishing specific actions and goals (objectives) established in a land use plan. A project may include several activities such as cutting and hauling trees and shrubs, planting trees, building trails, and fire treatment.

Regional Haze – Concentration(s) of fine particles in the atmosphere that reduce visibility over a wide geographic area.

Sensitive Populations – In the context of this document, those populations to whom smoke may present particular health risks.

Smoke Sensitive Areas (SSAs) – Areas designated by the FFS within which, for reasons of visibility, health or human welfare, smoke could adversely impact public safety e.g., interstates/highways, urban areas, airports, schools and hospitals.

Smoke Management Program or Plan – A basic framework of procedures and requirements for managing smoke from fires managed for resource benefits. The purposes of SMPs are to mitigate public safety hazards (e.g., on roadways and at airports) posed by smoke intrusions into populated areas; to prevent deterioration of air quality and NAAQS violations; and to address visibility impacts in Class I areas in accordance with EPA regional haze rules.

Source – In the context of this document, any place or object from which pollutants are released. A source can be a power plant, factory, dry cleaning business, gas station or farm. Cars, trucks and other motor vehicles are sources, and consumer products and machines used in industry can also be sources. Sources that stay in one place are referred to as stationary sources; sources that move around, such as cars or planes, are called mobile sources.

State Implementation Plan (SIP) – A detailed description of the programs a state will use to carry out its responsibilities under the Clean Air Act. State implementation plans are collections of the regulations and emission reduction measures used by a state to reduce air pollution in order to attain and maintain NAAQS or to meet other requirements of the Act. The Clean Air Act requires that the EPA approve each state implementation plan. Members of the public are given opportunities to participate in review and approval of state implementation plans.

Suppression – A management action to reduce fireline intensity, alter direction of spread, or partially or completely extinguish a fire to protect identified values.

Temperature Inversion – A weather condition often associated with smog episodes. In a temperature inversion, air doesn't rise because it is trapped near the ground by a layer of warmer air above it. Concentrations of aerosols including pollutants increase in this zone of trapped air. See also inversion.

Tribal Implementation Plan (TIP) – A document authorized by the CAA in which eligible Native American tribes adopt emission reduction measures necessary to attain and maintain NAAQS, and meet other requirements of the CAA for lands within tribal jurisdictions.

Volatile Organic Compound (VOC) – Any organic compound involved in atmospheric photochemical reactions. Photochemical reactions of VOCs with oxides of nitrogen will produce O₃, and with oxides of sulfur will produce PM.

Wildfire – An unplanned, unwanted wildland fire including unauthorized human-caused fires and escaped prescription fires.

Wildland Fire – Any non-structure fire that occurs in the wildland.

Wildland Urban Interface (WUI) – A line, area, or zone where structures and other human development meet or intermingle with wildlands.

Wildland – A rural area where development is generally limited to roads, railroads, power lines, and widely scattered structures. The land is not cultivated (i.e., the soil is disturbed less frequently than once in 10 years). The land may be neglected altogether or managed for such purposes as wood or forage production, wildlife, recreation, wetlands, or protective plant cover.

LITERATURE CITED

- Achtemeier, G. L., 1998: Predicting dispersion and deposition of ash from burning cane. *Sugar Cane*, **1**, 17-22.
- Clark, J. S., B. J. Stocks, and P. J. H. Richard. 1996. Climate implications of biomass burning since the 19th century in eastern North America. *Global Change Biology*, **2** (5), 433-422.
- De Laudonnier, R. 1587. A notable historie containing foure voyages made by certain French captains into Florida. Vols. 8 and 9 in *The principal navigations voyages traffiques and discoveries of the English nation*, R. Hakluyt, ed. And trans., 1904. Macmillian Publ. Co., New York.
- Draxler, R.R., 1992. Hybrid single-particle Lagrangian integrated trajectories (HY-SPLIT): Version 3.0 -- User's guide and model description. NOAA Tech. Memo. ERL ARL-195, 26 pp. and Appendices. [Available from National Technical Information Service, 5285 Port Royal Road, Springfield, VA 22161.].
- EPA. 1992. Prescribed burning background document and technical information document for prescribed burning best available control measures. Office of Air Quality Planning and Standards, Research Triangle Park, NC 27711. EPA-45012-92-003.
- EPA. April, 1998. Interim air quality policy on wildland and prescribed fires. Office of Air Quality Planning and Standards, Research Triangle Park, NC 27711.
- Heffter, J.L., and B.J.B. Stunder, Volcanic Ash Forecast Transport and Dispersion (Vaftad) Model, *Weather and Forecasting*, **8** (4), 533-541, 1993.
- Lavdas, L.G., 1996. *Program VSmoke—Users Manual*. GTR-SRS-6. U.S. Department of Agriculture, Forest Service, Southern Research Station. Asheville, NC 156 p.
- Ottmar, R. D., and R. E. Vihnanek. 1999. Stereo photo series for quantifying natural fuels. Volume VI: Southeastern United States. PMS 835. Boise, ID.
- Ottmar, Roger D.; Burns, Mary F.; Hall, Janet N.; Hanson, Aaron D. 1993. CONSUME users guide. Gen. Tech. Rep. PNW-GTR-304. Portland, OR: U.S. Department of Agriculture, Forest Service, Pacific Northwest Research Station. 17 p
- Peterson, J., and B. Leenhouts. 1997. What wildland fire conditions minimize emissions and hazardous air pollutants and can land management goals still be met? (Unpublished support document to the EPA Interim Air Quality Policy on Wildland and Prescribed Fires. August 15, 1997.)

Pyne, S.J. 1982. *Fire in America, a cultural history of wildland and rural fire*. Princeton Univ. Press, Princeton, NJ.

Pyne, S.J. February 2011. DoF: Florida's Fire Fulcrum. *A Fire History of America (1960 – 2011)*. Retrieved July 10th, 2013. <http://firehistory.asu.edu/dof-floridas-fire-fulcrum/>.

Sapkota, A., D. Williams, and T.J. Buckley. 2005. Tollbooth workers and mobile source-related hazardous air pollutants: How protective is the indoor environment. *Environ. Sci. Technol.* 39(9):2936-2943

USDA Forest Service, Southern Forest Experiment Station. 1976. Southern forestry smoke management guidebook. U.S. Department of Agriculture, Forest Service, Southern Forest Experiment Station. SE-10. 55PP

Therriault, S. and B. Schmidt, 2001, Wildfire smoke: a local health department meets the challenge, *Northwest Public Health*, Fall/Winter 2001 14-17.

Wade, Dale, and Hugh Mobley. 2007. *Managing smoke at the wildland-urban interface*. Gen. Tech. Rep. SRS-103. Asheville, NC. U.S. Dept. of Ag, Forest Service, Southern Res. Stn. 28 p.

APPENDIX

A. Simple Prescribed Burn Plan	46
B. Burn Plan for Pile Burners.....	48
C. National Weather Service, Fire Weather Web Sites	49
D. The Air Quality Index (AQI).....	50
E. Monitoring Sites In Florida — (July 2012).....	51



ADAM H. PUTNAM
COMMISSIONER

Simple Prescribed Burning Plan
Florida Department of Agriculture and Consumer Services
FLORIDA FOREST SERVICE RX FIRE PLAN
(P R E S C R I P T I O N)



Use Fire
Wisely

Forestry Center/District:		Authorization Number:			
Landowner:					
Address:					
Telephone Number	Section	Township	Range	County:	
Latitude			Longitude		
DEG	MIN	SEC	DEG	MIN	SEC
Acres to Burn:		Distance to Plow:		Previous Burn Date:	
Stand Description:					
Overstory Type:		Understory Type:		Height to Bottom of Crown:	
Fuel Description:		Fuel Model:		Topography and Soil:	
Purpose of the Burn:		Burn Objectives:			
Firing Techniques & Ignition Methods:					
Personnel Needs:			Equipment Needs:		
Maximum Crown Scorch Acceptable:			Passed Smoke Screening System:		
Listed Possible Smoke-Sensitive Areas:					
Special Precautions:					
Adjacent Landowners to Notify:					

MONITORING & EVALUATION PROCEDURES

PRE-BURN	BURN	POST BURN
WEATHER FACTORS	PREFERRED	ACTUAL
Surface Winds		
Transport Winds		
Minimum Mixing Height		
Dispersion Index (DAY)		
Dispersion Index (NIGHT)		
Maximum Temperature		
Minimum Relative Humidity		
Fine Fuel Moisture		
Rate of Spread		
Starting Time		
Burn Technique		
Flame Length		
Days Since Rain:	Date Burned:	Distance Plowed:

BURN CHECK LIST

FIRE BOSS: Initial each item to indicate compliance.

- All prescription requisites met (preparation and day of burn).
- Authorization obtained.
- Adjacent landowners notified within past seven days of plan to burn.
- Local contacts made day of burn to advise (FHP, SO, Fire Dept., media, etc.)
- Smoke screening performed and documented.
- All equipment required on scene and fully operational.
- Each crew member has proper personal gear and clothing.
- Low Visibility Risk Index checked.
- Smoke on the Highway signs in place, if needed.
- Test burn performed and fire behavior within expectations.

CREW BRIEFING

- Objectives of burn.
- Exact area of burn.
- Hazards discussed (volatile fuels, spotting potential, weak points in perimeter lines, terrain features, etc.).
- Crew Assignments made.
- Ignition technique and pattern. Holding method(s).
- Location of extra equipment, fuel, water, vehicle keys.
- Authority and communications.
- Contingencies covered including escape routes or procedures.
- Sources of nearest assistance. Nearest phone and emergency numbers.
- Special instructions regarding smoke management, contact with the public and others.
- Questions.
- Crew members given opportunity to decline participation (is there anything that is going to prevent full physical performance?).

Prescription Done by:	Certification Number:
Title:	Date:

CERTIFIED BURN MANAGER SIGNATURE:



Florida Department of Agriculture and Consumer Services
 Florida Forest Service

BURN PLAN FOR PILE BURNERS

ADAM H. PUTNAM
 COMMISSIONER

Burner's Customer Number:		Authorization Number:		
Burn Location:				
County:	Section:	Township:	Range:	
Type of Pile(s) to be Burned	<input type="checkbox"/> Agricultural	<input type="checkbox"/> Silvicultural	<input type="checkbox"/> Land Clearing	
Start Date and Time	Date:	Time:		
Expected End Date and Time	Date:	Time:		
Fuel Type				
Fuel Condition				
Soil Type	<input type="checkbox"/> Sandy	<input type="checkbox"/> Organic	<input type="checkbox"/> Other	
Soil Moisture	<input type="checkbox"/> High	<input type="checkbox"/> Medium	<input type="checkbox"/> Low	
Equipment Needs				
Personnel Need				
Meet Legal Setbacks				
Passed Smoke Screening				
Possible Smoke-Sensitive Areas				
Adjacent Landowners to notify				
Special Precautions				
WEATHER FACTORS				
	Acceptable Range		Preferred Value	Actual Value
	Max	Min		
Humidity (%)				
Temperature				
Wind Speed/Direction				
Dispersion Index				
Drought Index				
Days Since Rain				
Wind Direction Restriction or Other Restrictions				
Smoke Screening & Map Attached				

DACS-11051 10/08

NATIONAL WEATHER SERVICE, FIRE WEATHER WEBSITES

Florida NWS Fire Weather Offices

http://www.floridaforests-service.com/fire_weather/forecasts.html

Mobile, Alabama

http://www.floridaforests-service.com/fire_weather/NWS/nws_mob.html

Tallahassee, Florida

http://www.floridaforests-service.com/fire_weather/NWS/nws_tlh.html

Jacksonville, Florida

http://www.floridaforests-service.com/fire_weather/NWS/nws_jax.html

Tampa, Florida

http://www.floridaforests-service.com/fire_weather/NWS/nws_tbw.html

Melbourne, Florida

http://www.floridaforests-service.com/fire_weather/NWS/nws_mlb.html

Miami, Florida

http://www.floridaforests-service.com/fire_weather/NWS/nws_mia.html

Key West, Florida

http://www.floridaforests-service.com/fire_weather/NWS/nws_eyw.html

THE AIR QUALITY INDEX (AQI)

The AQI is a health-based index that provides a measure of air quality. The index is available at http://www.dep.state.fl.us/air/air_quality/airdata.htm. This site provides a map of AQI monitoring sites in FL, an explanation of the AQI and AQI pollutants with links to EPA websites and tables explaining the five categories of the index and the corresponding category breakpoint concentration in ppm or $\mu\text{g}/\text{m}^3$ for each pollutant. Clicking on any of the monitoring locations will provide the current outputs for the monitors at that location. Access to hourly air data collected at that site for any date is also available, with the concentration value and the corresponding AQI value.

2013 FDEP REGULATORY DISTRICTS, LOCAL AGENCIES, AND MONITORING SITES

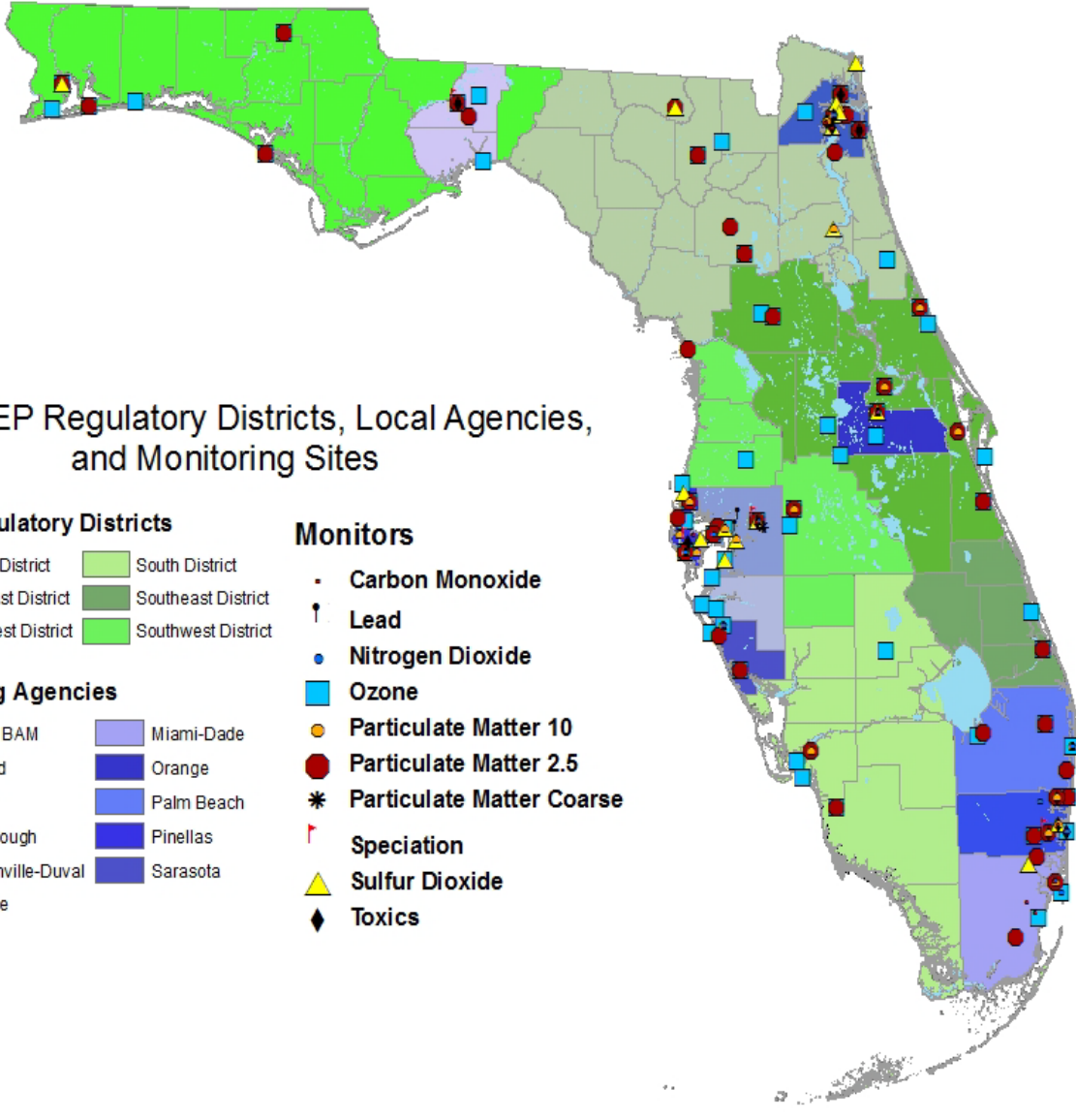

2013 FDEP Regulatory Districts, Local Agencies, and Monitoring Sites

FDEP Regulatory Districts

- Central District
- South District
- Northeast District
- Southeast District
- Northwest District
- Southwest District

Monitoring Agencies

- FDEP - BAM
- Miami-Dade
- Broward
- Orange
- Collier
- Palm Beach
- Hillsborough
- Pinellas
- Jacksonville-Duval
- Sarasota
- Manatee

Monitors

- Carbon Monoxide
- Lead
- Nitrogen Dioxide
- Ozone
- Particulate Matter 10
- Particulate Matter 2.5
- Particulate Matter Coarse
- Speciation
- Sulfur Dioxide
- Toxics

ACKNOWLEDGEMENT

The Florida Forest Service would like to acknowledge the assistance of the following in the development of this document:

The Department of Environmental Protection's Division of Air Resource Management reviewed the document for accuracy and was responsible for certifying the Florida Smoke Management Plan to the U.S. Environmental Protection Agency in January of 2014.

We would also like to thank Mr. Dale Wade who acted as redactor summus emeritus for the entire publication. Mr. Wade spent many hours poring over this document to make certain that the content and the language were the best they could possibly be, in order to be certain they reflected well on the State of Florida and the Florida Forest Service. We are grateful for the effort and time that he spent on the document.



FLORIDA FOREST SERVICE

3125 CONNER BOULEVARD

TALLAHASSEE, FL 32399-1650

(850) 681-5900

floridaforestservice.com

FLORIDA'S CERTIFIED SMOKE MANAGEMENT PLAN

FDACS-P- 01870

2014